

MINISTRY OF EDUCATION AND SCIENCE OF THE REPUBLIC OF  
KAZAKHSTAN

Satbayev University

Institute of Architecture and Civil Engineering named after T. Basenov  
Department of Civil Engineering and Building Materials

Naikpay Ramin

On the theme of "Shopping and entertainment complex"

To the diploma project

**EXPLANATORY NOTE**

Specialty 5B072900 – Civil Engineering

Almaty 2021

MINISTRY OF EDUCATION AND SCIENCE OF THE REPUBLIC OF  
KAZAKHSTAN

Satbayev University

Institute of Architecture and Civil Engineering named after T. Basenov  
Department of Civil Engineering and Building Materials

**ALLOWED TO PROTECT**

Head of Department

N.V. Kozyukova

Master of technical science, lecturer

« 30 » 05 2021 y

**EXPLANATORY NOTE**

to the diploma project

On the theme of "Shopping and entertainment complex"  
5B072900 - "Civil Engeneering"

Prepared by: Naikpay Ramin

Scientific Adviser: Zh. Mukhanbetzhanova  
Master of technique and technology

« 26 » 05 2021

Almaty 2021

MINISTRY OF EDUCATION AND SCIENCE OF THE REPUBLIC OF  
KAZAKHSTAN

Satbayev University

Institute of Architecture and Civil Engineering named after T. Basenov  
Department of Civil Engineering and Building Materials  
Specialty 5B072900 – Civil Engineering

**I APPROVE**

Head of Department

N.V. Kozyukova

Master of technical science, lecturer

« 30 » 05 2021 y.

**ASSIGNMENT**

**Complete a diploma project**

Student: Naikpay Ramin

Topic « Shopping and entertainment complex »

Approved by the Order of the Rector of the University No. 2131-b dated November 24, 2020.

The deadline for the completed work is May 13, 2021.

Initial data for the diploma project: Shymkent

Structural schemes of the building - frame-wall with cross-beams, structures are made of monolithic reinforced concrete, architectural solution.

List of questions to be developed:

a) Architectural and analytical part: basic initial data, space-planning solutions, heat engineering calculation of enclosing structures (outer wall), lighting calculation, calculation of the foundation option and depth of laying, justification of energy efficiency measures;

b) Calculation and design part: calculation and design of a column

c) Organizational and technological part: development of technological maps, construction schedule and construction plan;

d) Economic part: local estimate, object estimate, summary estimate;

List of graphic material (with exact indication of required drawings):

1. Facade, standard floor plans, parts 1-1 and 2-2 - 4 sheets.
2. KZ columns, specifications - 1 sheet.
3. Technical maps of earthworks and formwork, calendar plan, construction site plan - 4 sheets.

11 slides of work presentation are provided.

Recommended main literature: SP RK 2.04-01-2017 "Construction climatology", SN RK 2.04-04-2013 "Construction heat engineering", SN RK 2.03-30-2017 "Construction in seismic zones"

## **SCHEDULE**

Preparation of thesis (project)

No	Part	30%	60%	90%	100%	Note
1	<b>Architectural and analytical</b>	11.01.2021г.- 14.02.2021г.				
2	<b>Calculation and design</b>		15.02.2021г.- 23.03.2021г.			
3	<b>Organizational and technological</b>			24.03.2021г.- 01.05.2021г.		
4	<b>Economic</b>				01.05.2021г.- 09.05.2021г.	
5	<b>Pre-defense</b>	10.05.2021г.-13.05.2021г.				
6	<b>Anti-plagiarism, norm control</b>	17.05.2021г.-18.05.2021г.				
7	<b>Quality control</b>	26.05.2021г.-31.05.2021г.				
8	<b>Defense</b>	01.06.2021г.-11.06.2021г.				

## Signatures

consultants and the normative controller for the completed diploma work (project) with an indication of the parts of work (project) related to them

Name parts	Consultants, I.O.F. (academic degree, rank)	the date signing	Signature
Architectural and analytical			
Calculation and design			
Organizational and technological			
Economic			
Norm controller			
Quality control			

Scientific adviser

Zh.Mukhanbetzhanova

The task was accepted

for execution student

Naikpay Ramin

Date:

"\_30\_" \_05\_ 2021 y

## Тұжырымдама

« Сауда-ойын-сауық кешені » жобасы сурет бөлімі мен төрт негізгі бөлімнен тұрады. Жобаның сындарлы бөлігі қазіргі кезде Қазақстанда жүзеге асырылып жатқан еуро коды нормасы бойынша есептеледі. Сәулет бөлімі Revit бағдарламасы бойынша жасалған, ал конструктивті бөлім Revit 2021 есептеу бағдарламасымен жүзеге асырылады. AutoCAD Architecture 2020 бағдарламасы бойынша басқа жолдар. Коэффициенттерді есептеу кезінде ұлттық өтінімге сәйкес алынады (НА РК). Бағаланған бөлік ABC-4 бағдарламасы бойынша құрастырылды.

Техникалық-экономикалық ішкі бөліктер: -

- Ғимараттың ұзақтығы - 420 күн.

## АННОТАЦИЯ

Проект «Торгово-развлекательный комплекс» состоит из чертежного отдела и четырех основных секций. Конструктивная часть проекта рассчитана по норме Еврокода, которая сейчас внедряется в Казахстане. Архитектурный отдел разработан по программе Revit, а конструктивный отдел реализован по расчетной программе Revit 2021. Остальные строчки по программе AutoCAD Architecture 2020. При расчете коэффициенты получаются по национальной заявке (НА РК). Оценочная часть составлена по программе ABC-4.

Технико-экономические внутренности: - -

Срок строительства 420 дней.

## ANNOTATION

The project " Shopping and entertainment complex " consists of a drawing department and four main sections. The constructive part of the project is calculated according to the Euro code norm, which is currently being implemented in Kazakhstan. The architectural department was developed under the Revit program, and the constructive department is implemented by the Revit 2021 calculation program. Other lines by program AutoCAD Architecture 2020. When calculating the coefficients are obtained according to the national application (NA RK). The estimated part was compiled according to the ABC-4 program.

Technical-economic insides are: -

The duration of the building is 420 days.

## CONTENT

Introduction	8
1 Purpose of the project	9
2 location of project	12
3 Climate of the city	14
4 Dendrological composition and characteristics of plants	20
5 Architectural and construction section	22
5.1 Constructive section	23
5.2 Description of the applied structures	24
5.3 Structural part (above the 0.000 mark)	27
6 Safety and labor protection	30
6.1 General	30
6.2 The main sections of life safety	30
6.3 Ensuring safety along escape routes	31
6.4 Fire protection	31
6.5 Lighting	32
6.6 Protection of the territory from the harmful effects of noise	32
6.7 Social protection in the entertainment center	33
7 Vertical stiffness diaphragms	34
7.1 Guidelines for calculating vertical stiffness ties	34
7.2 Collecting loads	35
7.3 Calculation of a vertical diaphragm with a height of 24m	36
7.4 Calculation of the diaphragm section within the floor	40
8 Technological part	43
9 Method choice of complex mechanized earthworks process	45
10 Selection of the excavator	46
Conclusion	49
References	50

## INTRODUCTION

Construction is one of the most important sectors of the national economy and provides for the expansion, reconstruction and renewal of existing fixed assets.

The role of capital construction in the development of all industries, increasing the productivity of public labor, raising the level of material and cultural conditions is special.

Today's construction consists of a very complex set of works. Modern economic law, on the one hand, requires that some work be synchronous, and it is carried out only in the case of the organization of labor at the scientific level.

The main type of organization is a single set of rules and rules for the design of production organization, construction management and planning system. The growth of workload, the complexity of the facilities today requires the improvement of management methods. One of the main methods is the branch chart method. This method is one of the most effective methods of organization and planning of production.

Increase in the volume and capacity of complexes under construction and requirements to them, reduce construction time, improve the quality of construction, increase the level of construction, equipping construction companies with high-tech machines and mechanisms, introduction of new technological materials and structures, involvement of specialized organizations in construction and individual coordination work in making effective planning decisions.

Advanced technological process requires improving the quality of administrative, industrial buildings, spatial planning, architectural, aesthetic and design solutions. The growth of the role of capital construction as an industrial sector is determined by this. One of its important centralized tasks is to ensure the growth of the production capacity of the Republic of Kazakhstan on a completely modern basis. Improving the efficiency of capital financing is a very difficult task. This includes rational decisions on the direction, structure and location, as well as a high level of development of design solutions, along with a reasonable choice of construction object. Thus, a multifaceted comprehensive scientific and technical program has been developed and should be implemented in the previous five years in a single cycle in accordance with the stage "science - design - experimental - production - production.



## **1 Purpose of the project**

Creation of a park on the territory of the Shymkent city, as a place for mass recreation of the townspeople.

Project development solves the assigned tasks:

- Carrying out a pre-project analysis, which includes: studying the location of the object in the city, the natural and climatic characteristics of the city, the urban planning situation of the design object (characteristics of the existing development and the existing landscaping), field research, as well as studying the experience of landscaping abroad and domestic experience;

- Revealing the architectural and planning solution of the object territory: general plan, functional zoning of the territory, location of the main entrances, convenient organization of the road and path network.

- Creation of an architectural object to attract a massive flow of citizens.

- Formation of volumetric-spatial structure.

- Functional zoning of the territory.

The architectural and design solution of the object was developed taking into account building codes and regulations (SNiP) and is reflected in the drawings and project diagrams.

The initial materials for the project were topographic survey in tif format, cosmographic survey from Google Earth, materials of own observations and measurement literature from Internet sources.

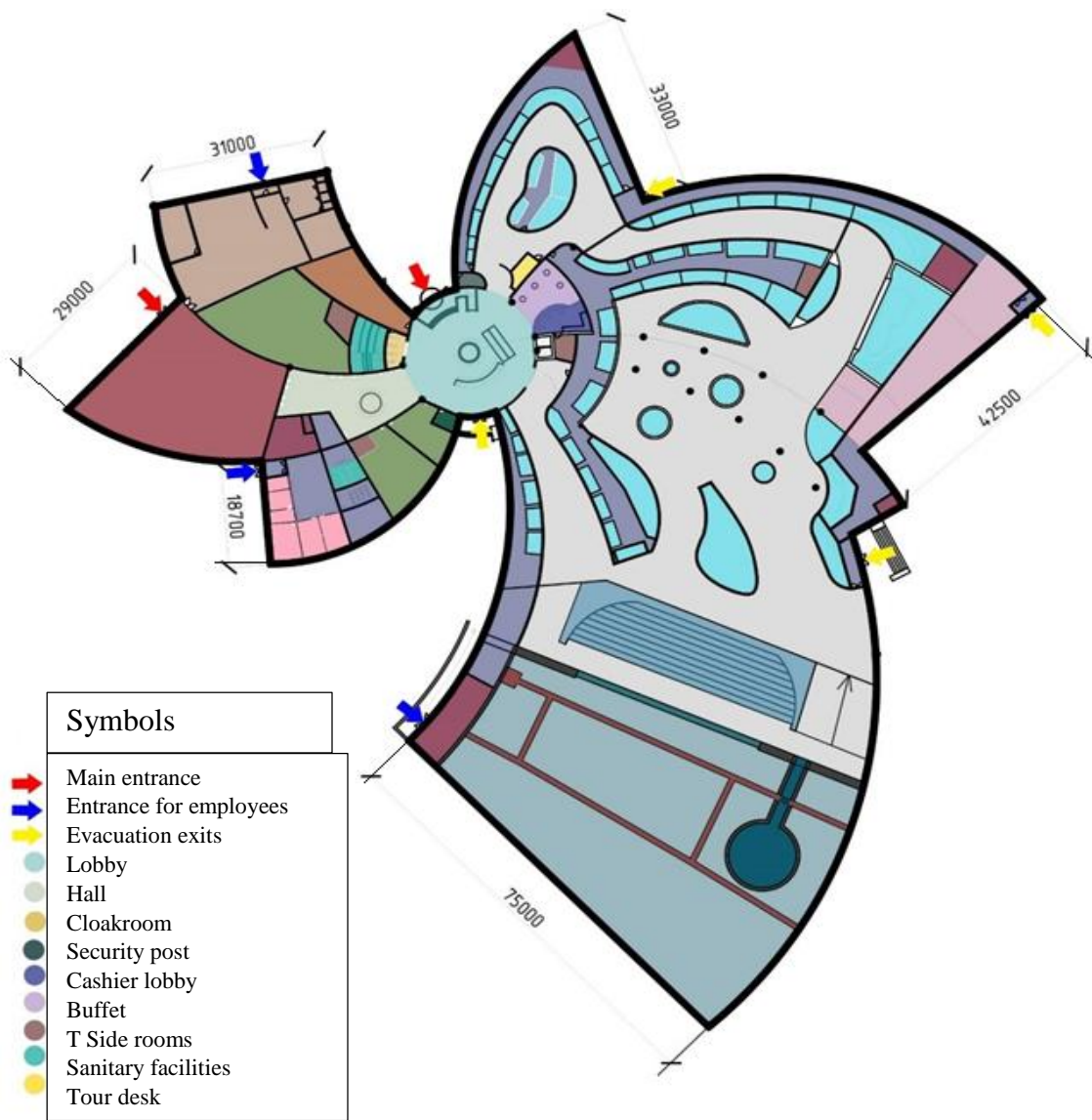
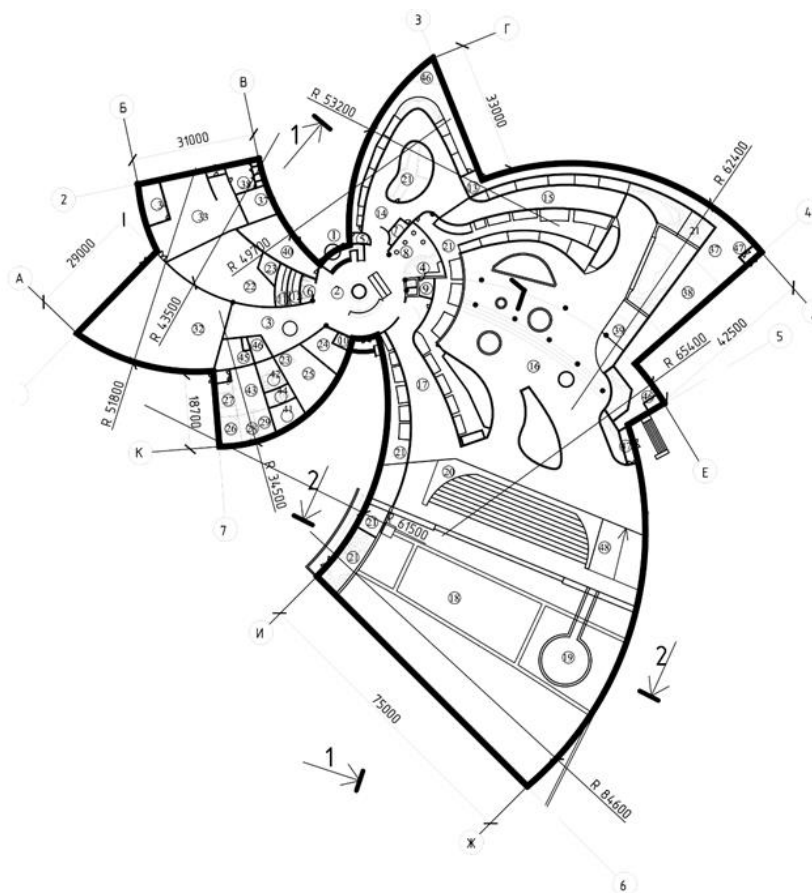

Figure 1. Full plan



1. Entrance	25. Coral reef , Study room
2. Lobby	26. Director's office
3. Hall	27. Deputy director office
4. Cashier lobby	28. Accounting office
5. Security room	29. Manager's office
6. Cloakroom	30. Guides room
7. Tour disk	31. Research staff room
8. Buffet	32. Restaurant
9. Utility room	33. Restaurant kitchen
10. Souvenir shop	34. Chef's office
11. man's Toilet	35. Locker room
12. womens Toilet	36. Warehouse
13. Corridor	37. Reception room
14. Exhibition hall ( seas )	38. Isolator
15. Exhibition hall ( fishes )	39. Medical center
16. Exhibition hall ( Oceanic fishes )	40. Cafe shop
17. Exhibition hall ( Coral reefs )	41. Staff room
18. Main pool	42. Staff sanitary facilities
19. Underwater room	43. Staff lobby
20. Amphitheater	44. Staff wardrobe
21. Auxiliary room at aquariums	45. Electric workshop
22. Research laboratory	46. Electric box
23. Store room	47. Tambour
24. Auditorium	48. Ramp

Figure 2. plan parts

## 2 Project location

I have a project to plan in Shymkent city of Kazakhstan. It is near the border with Uzbekistan. It is one of three Kazakh cities which have the status equal to that of a region. It is the third most popular city in Kazakhstan, behind Almaty and Nur-Sultan, with an estimated population of 1,002,291 as of June 1, 2018. According to regional and city officials, the millionth resident of Shymkent was born on 17 May 2018. It is a regional cultural center.



Chimkent is situated 690 kilometers (430 mi) west of Almaty and 1,483 kilometers (920 mi) south of Nur-Sultan. It is also 120 kilometers (75 mi) to the north of Tashkent, Uzbekistan.

Chimkent was founded in the twelfth century as a caravanserai to protect a nearby Silk Road trade town, Sayram, 10 km to the east. Chimkent grew as a market center for trade between Turkic nomads and the settled Sogdians.

Chimkent was founded as a hub for economic development in South Kazakhstan in the 20th century, and rapid growth was evolving in the second half of the century. To date, there are about 70 factories, plants and other manufacturing companies in the area.

A settlement on the territory of modern Chimkent already existed at the turn of the 11th – 12th centuries. At the same time, there is a hypothesis about its earlier establishment based on the burials found during the archaeological excavations, which, according to experts, date back to the 5th – 6th centuries.

Chimkent (Shymkent), as a city-settlement already existed in the 6th century AD. Its name links to the famous traveler Xuan Jiang, who mentioned it in his notes about Isfijab - Sairam.

In 1914, in honour of the 50th anniversary of Shymkent becoming part of the Russian Empire, the city was named Chernyaev, but in 1924 the Soviet authorities returned to the city its former name.

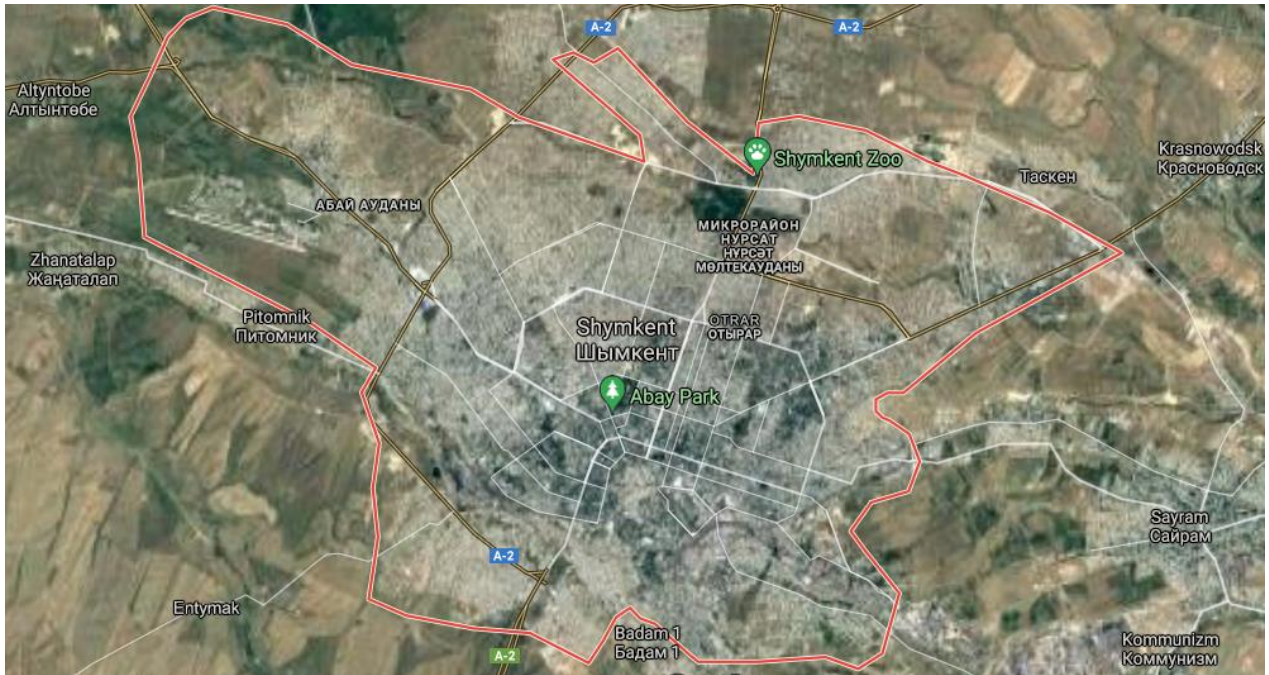
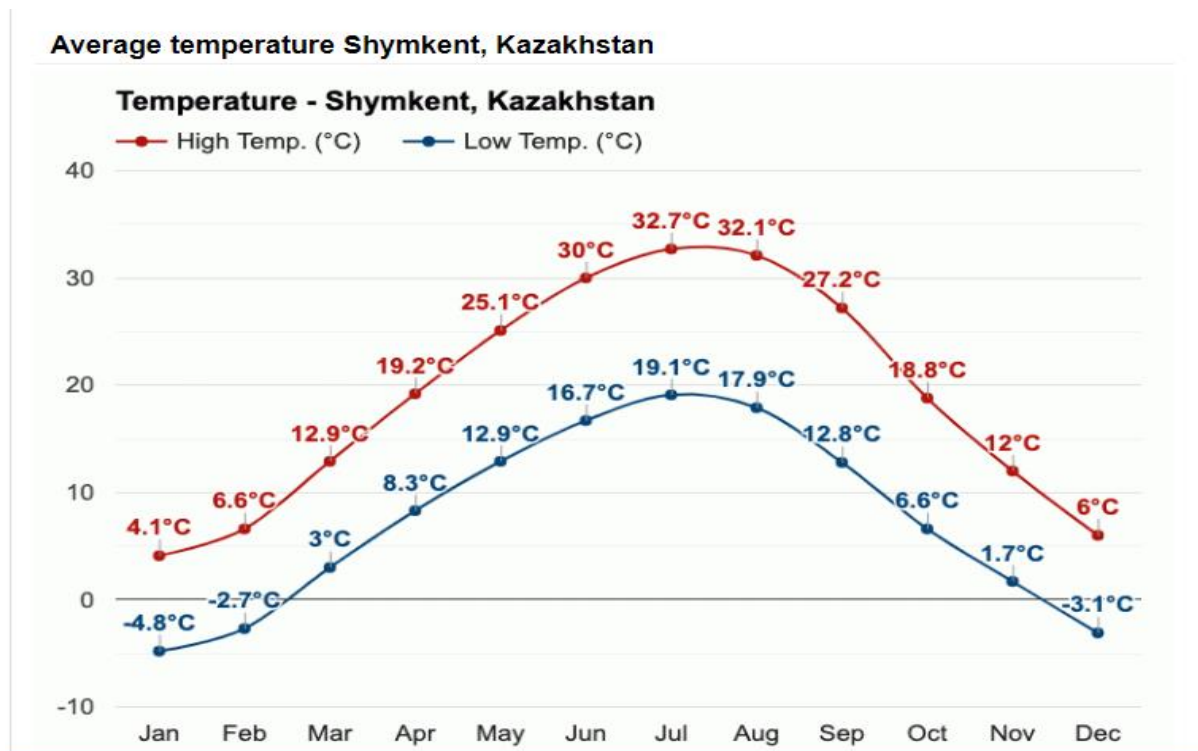

Figure 4-location of building in the city

### 3 Climate

Shymkent features a humid continental climate bordering on a Mediterranean climate. Shymkent features hot, relatively dry summers and cold winters. Winters here are noticeably warmer than in more northerly cities like Almaty and Nur-sultan, with the mean monthly temperature during the city's coldest month (January) averaging around  $-1\text{ }^{\circ}\text{C}$  ( $30.2\text{ }^{\circ}\text{F}$ ). Winter snowfalls are common, although rainfall during that season occurs mixed in with that. Shymkent averages just under 600 millimeters (23.62 in) of precipitation annually.

Climate data for Shymkent (1981–2010)														[hide]
Month	Jan	Feb	Mar	Apr	May	Jun	Jul	Aug	Sep	Oct	Nov	Dec	Year	
Record high °C (°F)	22.2 (72.0)	25.2 (77.4)	30.7 (87.3)	33.0 (91.4)	37.8 (100.0)	43.0 (109.4)	42.6 (108.7)	42.2 (108.0)	39.2 (102.6)	34.4 (93.9)	30.5 (86.9)	25.4 (77.7)	43.0 (109.4)	
Average high °C (°F)	4.1 (39.4)	6.6 (43.9)	12.9 (55.2)	19.2 (66.6)	25.1 (77.2)	30.0 (86.0)	32.7 (90.9)	32.1 (89.8)	27.2 (81.0)	18.8 (65.8)	12.1 (53.8)	6.0 (42.8)	18.9 (66.0)	
Daily mean °C (°F)	-0.7 (30.7)	1.6 (34.9)	7.6 (45.7)	13.6 (56.5)	19.1 (66.4)	23.7 (74.7)	26.3 (79.3)	25.3 (77.5)	19.9 (67.8)	12.3 (54.1)	6.4 (43.5)	0.9 (33.6)	13.0 (55.4)	
Average low °C (°F)	-4.8 (23.4)	-2.7 (27.1)	3.0 (37.4)	8.3 (46.9)	12.9 (55.2)	16.7 (62.1)	19.1 (66.4)	17.9 (64.2)	12.8 (55.0)	6.6 (43.9)	1.7 (35.1)	-3.1 (26.4)	7.4 (45.3)	
Record low °C (°F)	-31.1 (-24.0)	-28.9 (-20.0)	-23.9 (-11.0)	-5.0 (23.0)	-2.8 (27.0)	5.5 (41.9)	7.8 (46.0)	6.2 (43.2)	-1.1 (30.0)	-12.0 (10.4)	-30.0 (-22.0)	-26.1 (-15.0)	-31.1 (-24.0)	
Average precipitation mm (inches)	73 (2.9)	70 (2.8)	83 (3.3)	69 (2.7)	56 (2.2)	16 (0.6)	12 (0.5)	4 (0.2)	10 (0.4)	41 (1.6)	67 (2.6)	75 (3.0)	576 (22.7)	
Average rainy days	5	7	9	9	9	5	4	3	3	6	6	6	72	
Average snowy days	8	7	4	0.3	0	0	0	0	0	0.4	3	6	29	
Average relative humidity (%)	75	73	67	63	56	44	39	34	39	55	69	75	57	



### Average humidity Shymkent, Kazakhstan

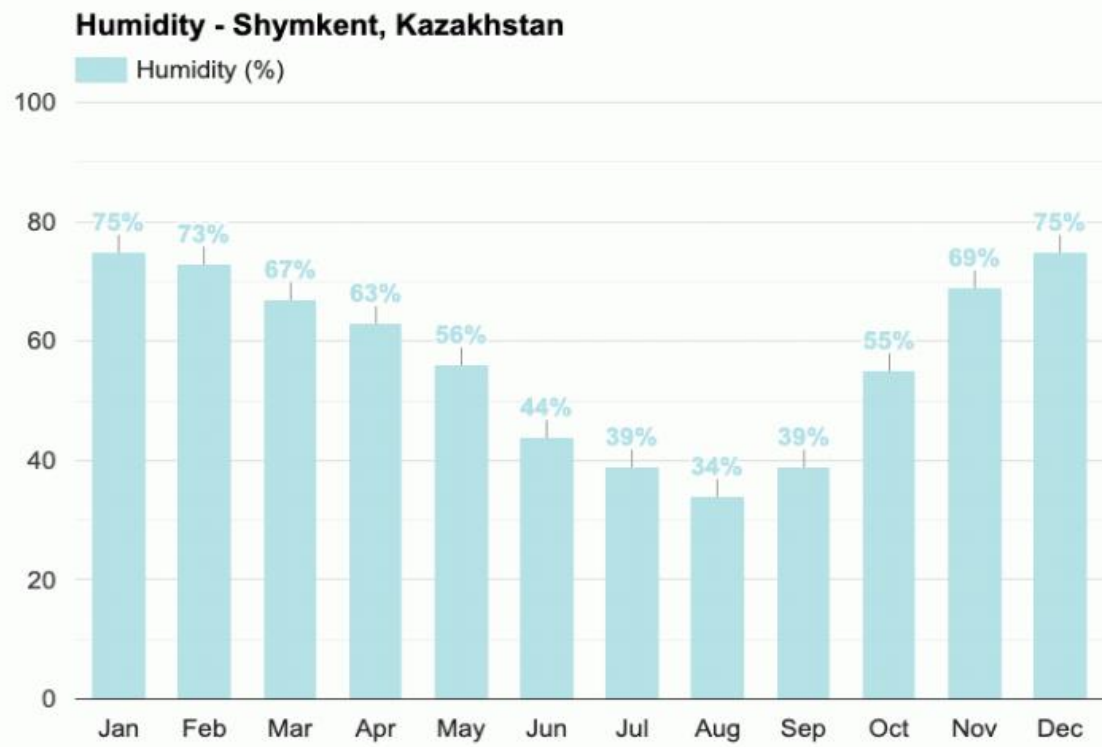

### Average rainfall Shymkent, Kazakhstan

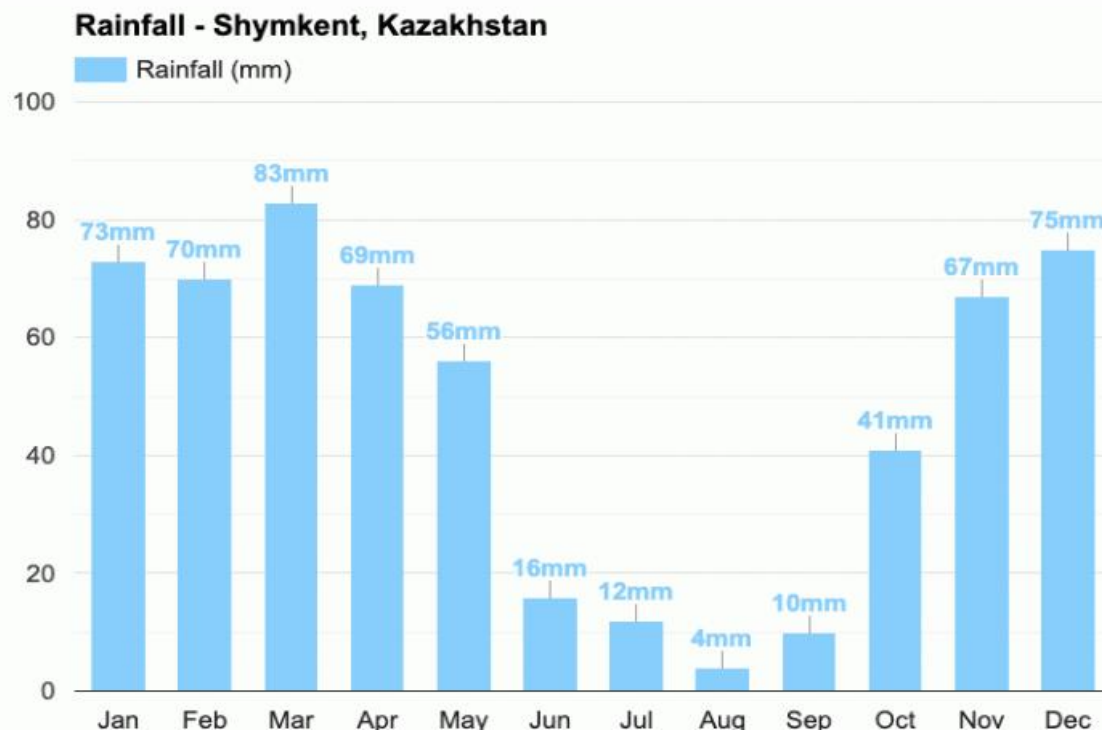

Project Location

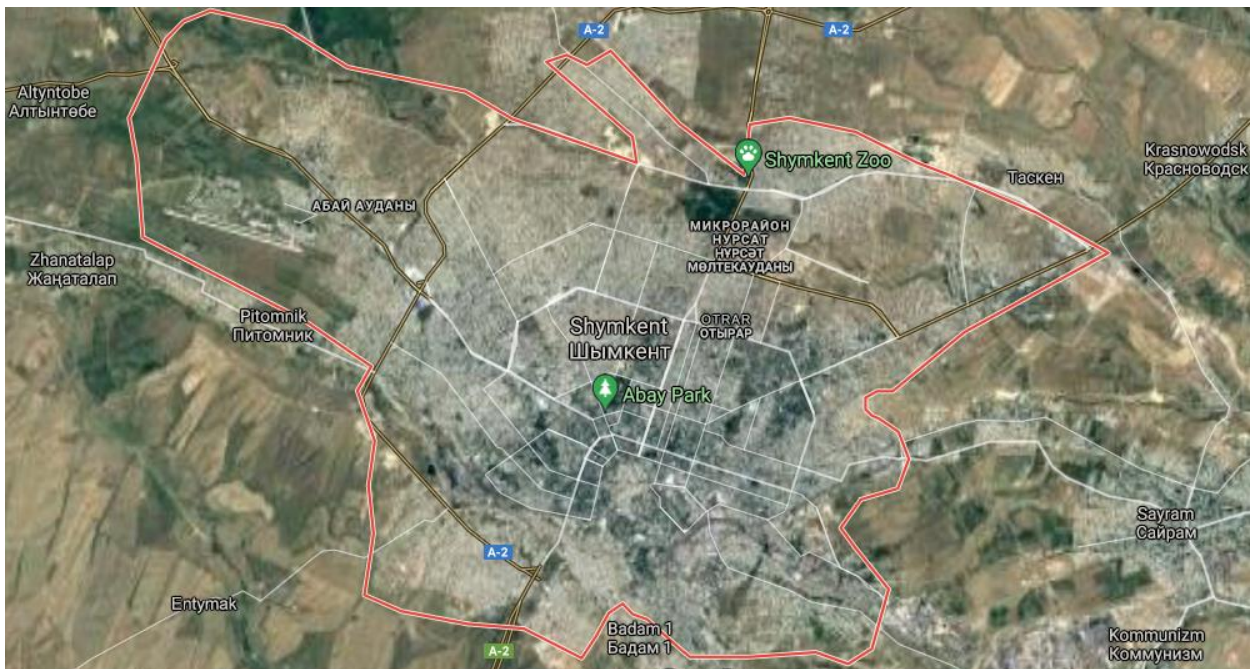

My project is located in the back side of Aquapark that is located in the center of the city, nearby abay park in front of service center (Центр обслуживания населения ).



The project provides for the placement of a public toilet on the territory of the park. Due to the area of the park, which is more than 100 hectares. In the park, 40% of the



existing trees have been preserved. They were elm. But for a variety of flora, new types of trees and shrubs were planted.

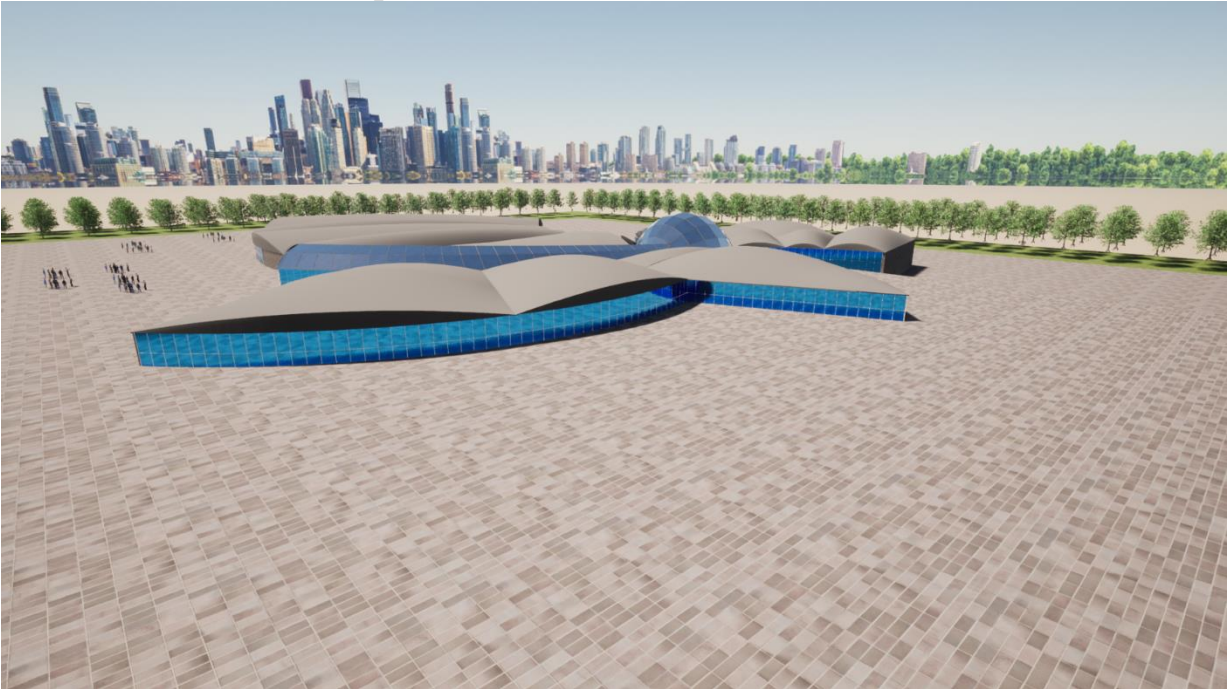

Figure 3. General form



Figure 4. Section

Table 2 - Projected balance of the territory

Functional zones of the park by type of use	The size of the land plot of the park zone, ha	% of the total area of park
Cultural and entertainment zone events	6,3	9,4
Zone of mass events (spectacles, attractions, etc.)	7,16	10,6
Fitness and Wellness Zone events	5,63	8,4
Recreation area for children	0,7	1,1
Walking area	35,6	53
Economic zone	0,41	0,7

According to the rules for counting the number of visitors, this number should be calculated at the rate of 10-15% of the number of citizens living within a 30-minute accessibility of the park. The number of visitors to the park is approximately 22,800. The estimated number of one-time visitors to the parks territory should be taken, person / ha, not more: for city parks - 100. Therefore, in a project with a total area of 110 hectares, but I take into account the size of the reservoir, which is 39% of the entire territory. The estimated number of one-time visitors to the park is 6,700 people.

The project provides for the placement of a public toilet on the territory of the park. Due to the area of the park, which is more than 100 hectares.

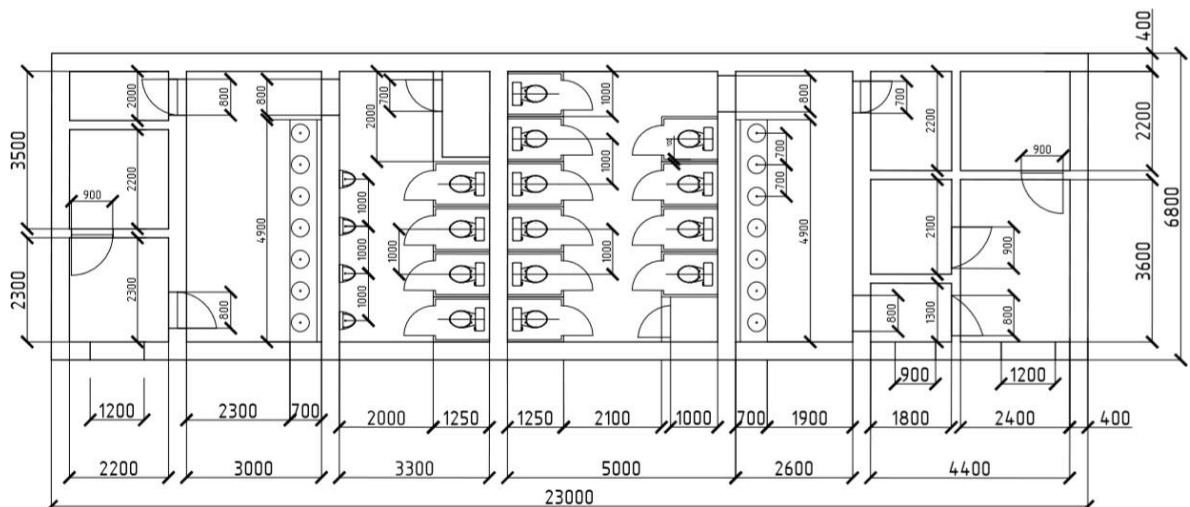

Figure 32. Plan of a public toilet

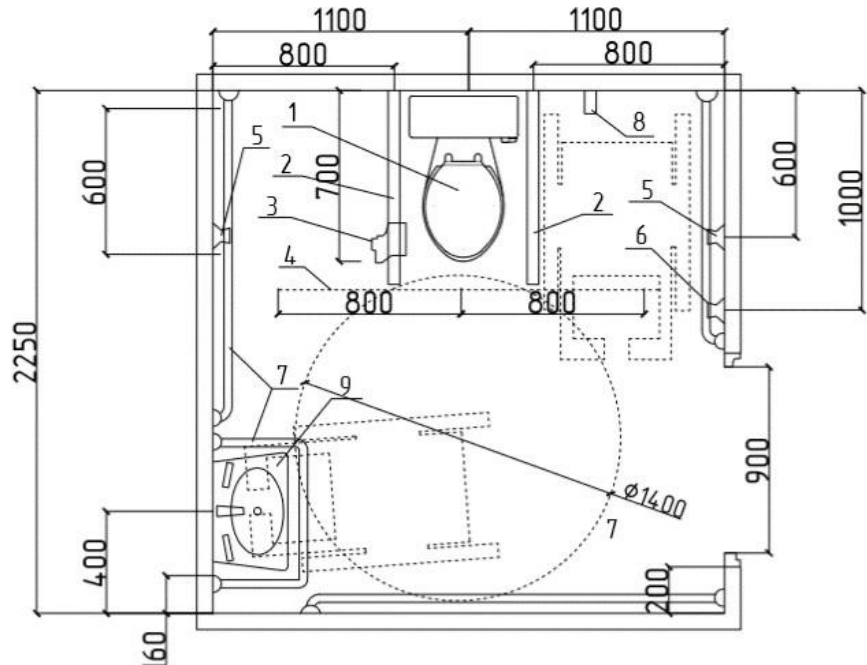

Figure 33. Toilet plan for people with limited mobility

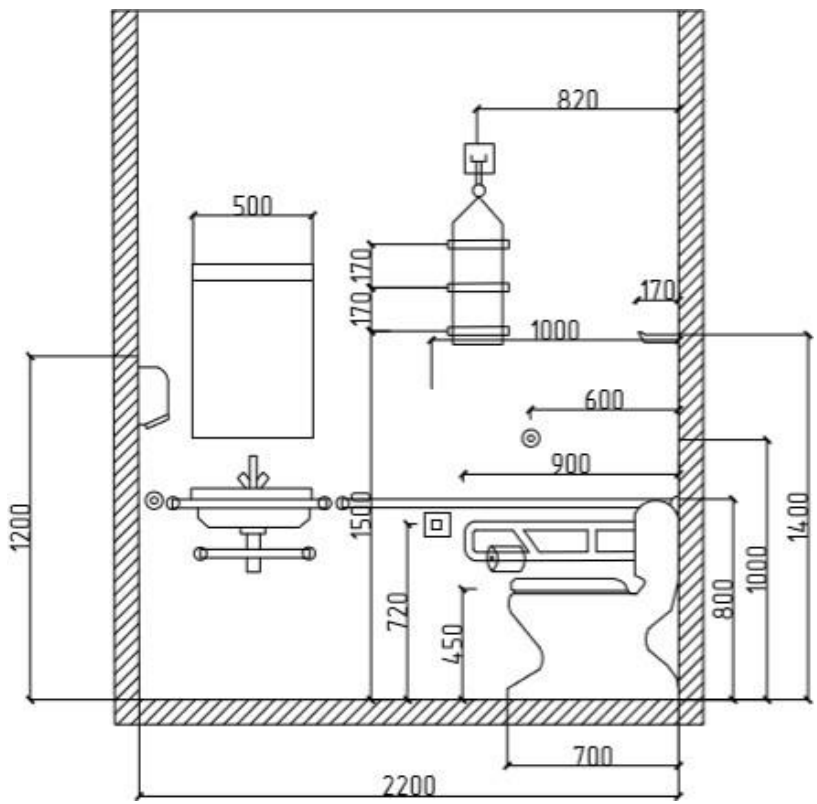

Figure 34. Sectional view of a toilet cabin for people with limited mobility

#### 4 Dendrological composition and characteristics of plants

The project uses a classic decorative lawn, as well as a flowering Moorish lawn in the area.

Classic decorative lawn - make up the main fund of landscaping objects, on which volumetric elements of the composition are placed - trees, shrubs, flower beds, small forms, equipment. The classic lawn was chosen so that visitors to the park could relax and have picnics on the grass.

In the park, 40% of the existing trees have been preserved. They were elm. But for a variety of flora, new types of trees and shrubs were planted.

Shrubs and trees were selected that have a blue and white color: hydrangeas, canadian irga, Hungarian lilac, etc. All vegetation is presented in the assortment list of trees and shrubs.

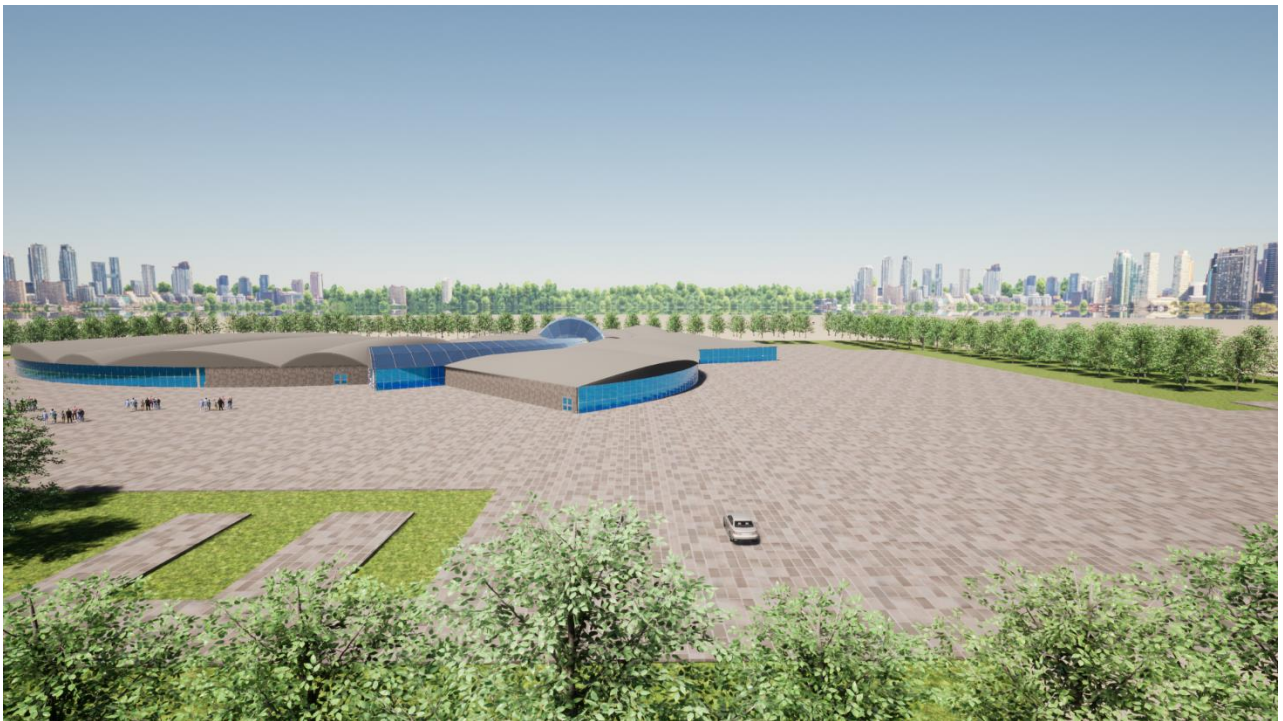

Figure 6

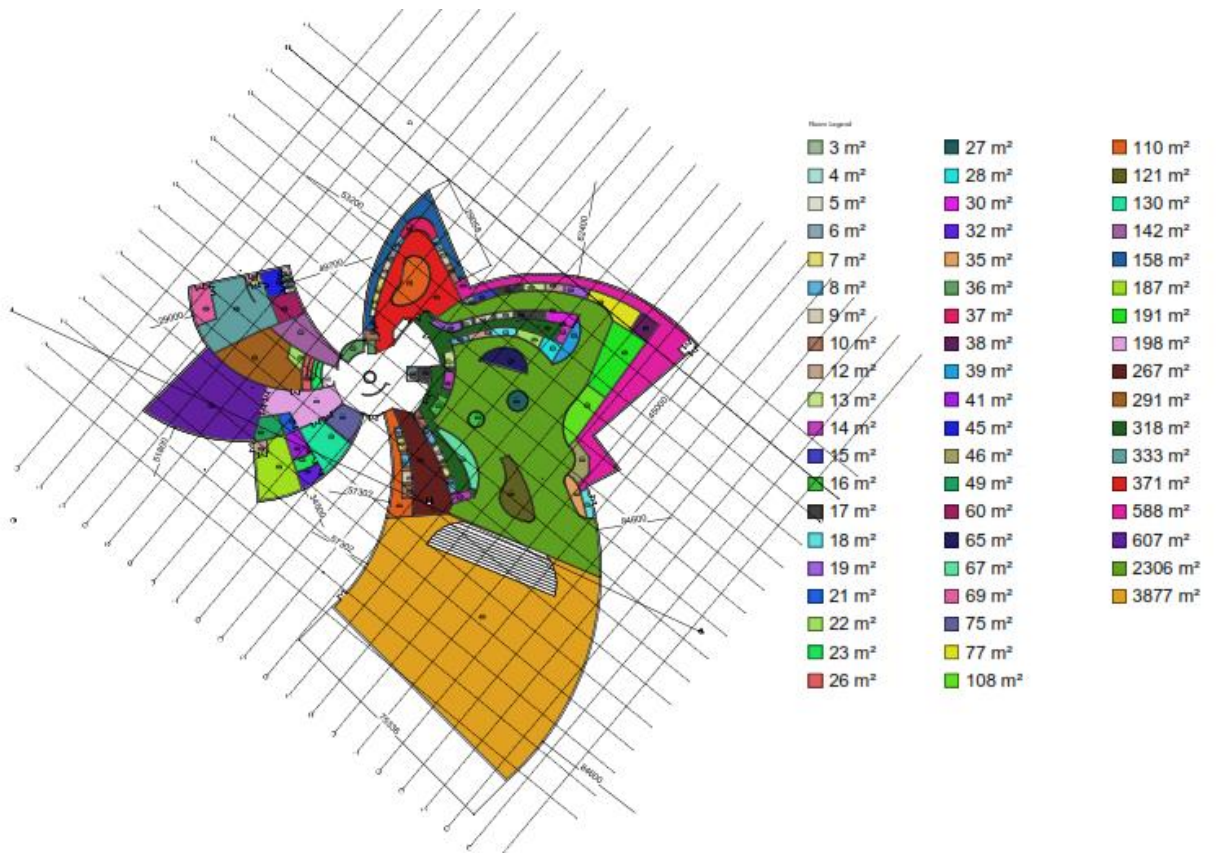

Figure 5

## 5 Architectural and construction section

The graduation project was developed for the construction of " Shopping and entertainment center " located at: Shymkent, at the intersection of streets with design names E10, E305, E306, is located on the allotted territory of 110 hectares. Building characteristic: according to Order No. 517 of December 20, 2016 "On Amending Order No. 165 of the Minister of National Economy of the Republic of Kazakhstan dated February 28, 2015" On approval of the Rules for determining the general procedure for classifying buildings and structures as technically and technologically complex objects. The degree of fire resistance of a building is II in accordance with SN RK 2.04-01-2017“Fire safety of buildings and structures. The graduation project is designed for the following construction conditions: Humidity zone - normal; Climatic region - IV(IVG): temperate continental climate; wind speed zone IV; Climatic parameters of the cold season: air temperature of the coldest day: -17.7 °C; air temperature on the coldest five-day period: -14.3 °C; the construction area is seismic hazard, the construction site is located in the residential and administrative buildings zone, the land plot Relief is calm.

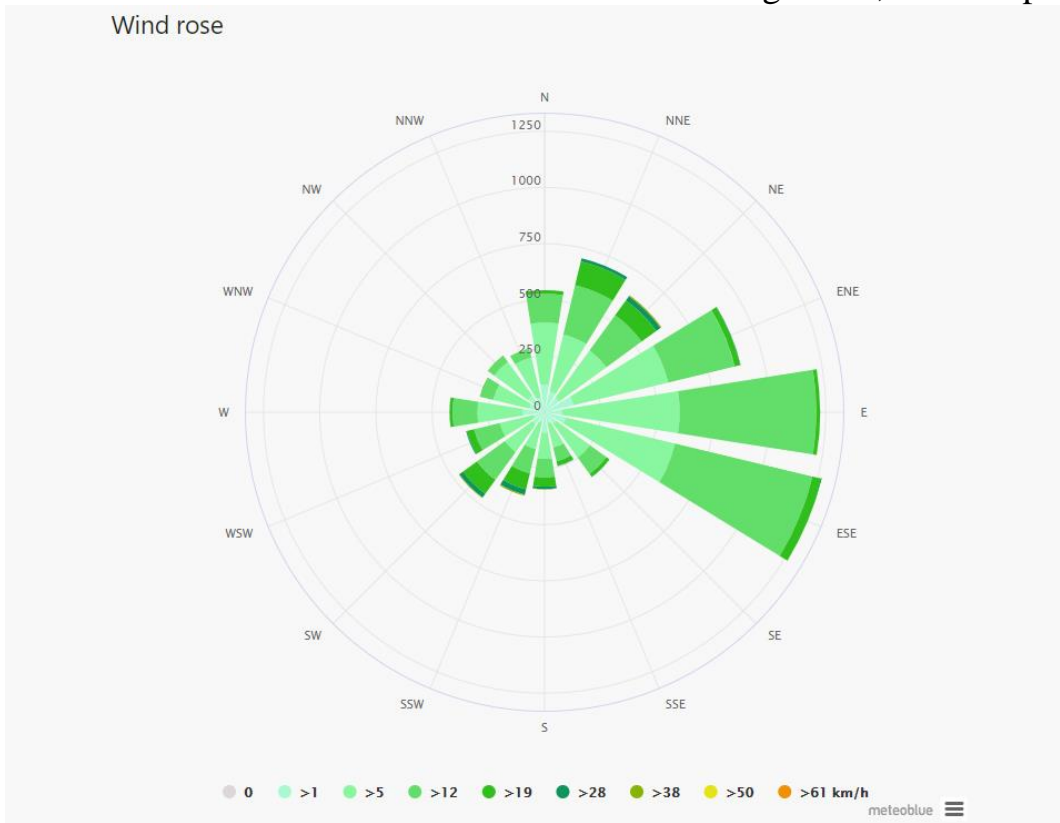

Figure 7- Wind rose according to the weather station of city

## 5.1 Constructive section

Table 1- Basic materials and structures

Constructions	Type	Material	Dimensions of elements, spans, steps, etc.
Foundation	Strip monolithic foundation	Artificial material: concrete B25	Foundation thickness: 500mm. Transverse step arm: 200mm Arm longitudinal step: 200mm. Waterproofing: roofing felt
Exterior walls	Monolithic	B25 Concrete	400 mm thick
Partitions	Collapsible, on a metal frame	Non-concrete material: sheet	Wall thickness: 200 mm
Stairs	Prefabricated	Reinforced Concrete	Width: 1300mm
Frame columns	Steel columns of constant cross-section	Steel	Column grid 9x9 m.
Beams and trusses	Truss with parallel belts. With wide shelf brands.	Steel	Section dimensions: 100x400 mm
Slabs	Prefabricated	Reinforced Concrete	Thickness: 150mm
Roof	Shells of double curvature. Non-exploited	Polycarbonate	Plate thickness 10mm
Insulation	Strips of stone wool lamellas	Stone wool "FACADE LAMELLA "	thickness: 200 mm
windows	Stained glass windows on a metal frame	Stemalit Glass	Glass thickness 3.5 mm. Double glazing
Doors	1. Round 2. Input 3. Evacuation	1. Tempered glass 2. Tempered glass in rim frame 3. Aluminum Door	glass thickness 6 mm
Facade finishing	Sandwich panels		Thickness 110 mm

## **5.2 Description of the applied structures**

Structural part (below the 0.000 mark)

The foundation in the project is a monolithic belt made of concrete grade B25.

The thickness of the foundation is taken as 500mm. For a reinforced concrete slab, reinforcement is used in a transverse and longitudinal step of 200 mm. Most of the outer walls are buried in the soil, forming a basement room. The width of the wall is taken as 400mm. Since the soil is saturated with water, it is necessary to waterproof the foundation and basement walls. Measures are being designed to protect the foundation and walls from groundwater: papered and continuous carpet made of PVC membrane. These activities are shown in the drawing of the node 1-1.

(basement unit with an abutment of the floor slab), unit 2-2 (unit of a monolithic foundation slab), unit 3-3 (unit for waterproofing the outer basement wall).

Node 1-1. Foundation node with an abutment of the floor slab.

The general plan was developed in accordance with the urban planning situation and the required orientation of the premises, the master plan for the development of areas, taking into account the landscaping and landscaping in accordance with the requirements of SN RK 3.02-07.2014 "shopping and entertainment center structures" and SP RK 3.01-101-2013 "Urban planning. Improvement and greening of the site envisaged by the project reduces the general dust content and eliminates local foci of dust.



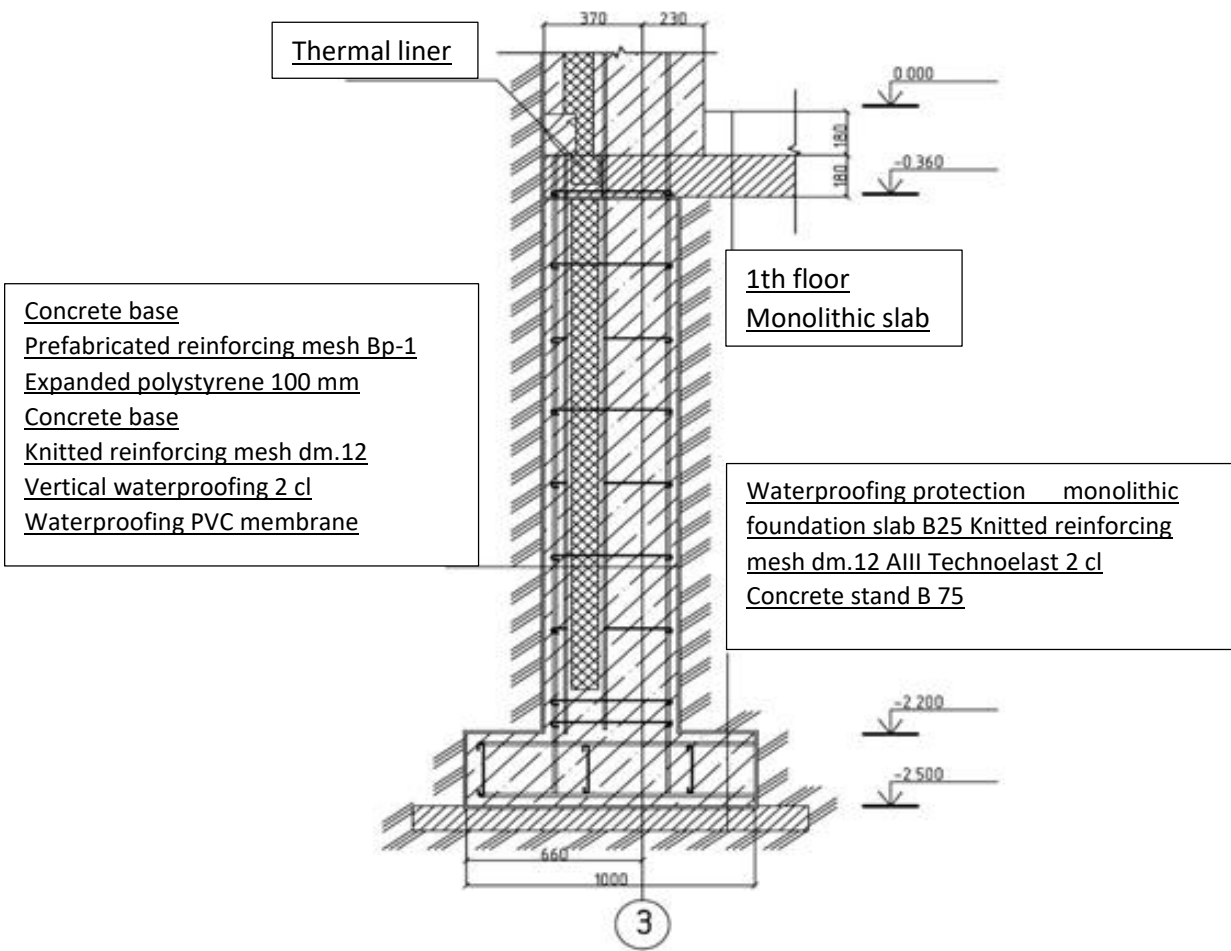

Figure 8. Node 1-1. Foundation node with abutting floor slab  
 Node 2-2. Monolithic Foundation Slab Node

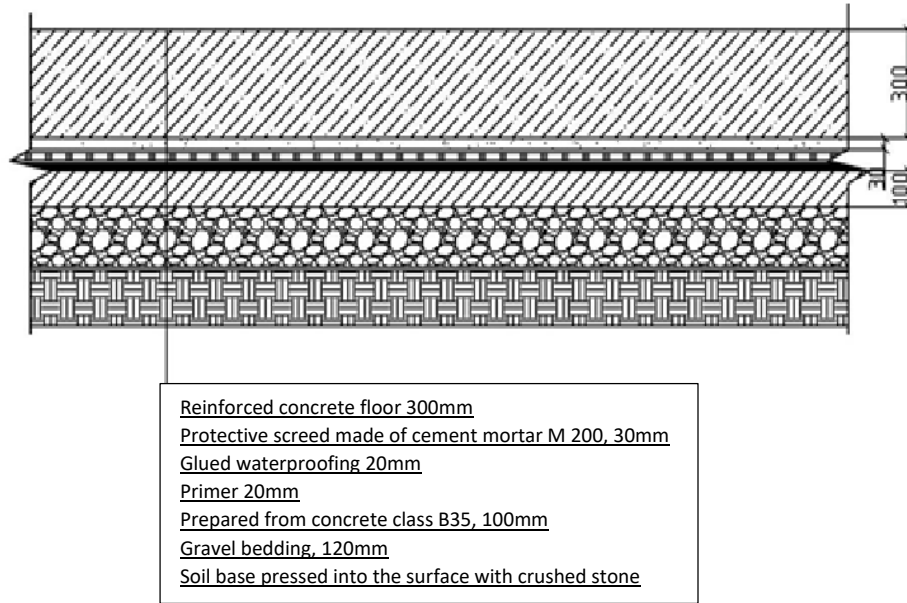

Figure 9. Node 2-2. Monolithic foundation slab assembly.

Node 3-3. Exterior Wall Waterproofing Assembly Revised

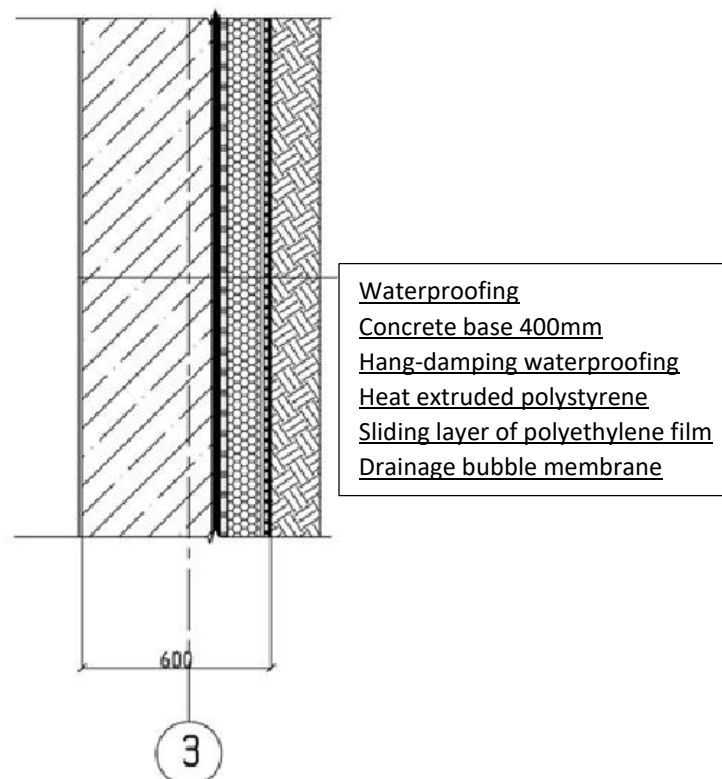

Figure 10. Node 3-3. Exterior wall waterproofing unit

### 5.3 Structural part (above the 0.000 mark)

Partitions that divide the internal space of the building into separate rooms and perform only enclosing functions. The project uses collapsible partitions. They are assembled from separate structural elements, which, if necessary, can be easily dismantled and assembled elsewhere. Collapsible partitions are made of frame, followed by sheathing with sheet materials, cement particle boards (DSP). The partition thickness is 200 mm.

Metal profiles of aluminum alloys are used as a frame. The step of the frame racks is 600 mm. On both sides of the frame, sheathing made of sheet materials, cement-bonded particle boards (DSP), are attached.

The large-span covering of the halls is arranged along a shell of double curvature. They are supported by columns that follow the outline of the building. The spans are equal to 75,42,33,31,29 meters. Protection of metal structures against corrosion should be carried out by painting with PF 115 enamel over the primer layer. The braces of the metal truss are directly adjacent to the lower and upper chords. According to the method of connecting the elements in the nodes, the project truss is of the welded type. For these trusses, rectangular bent-closed sections are used, since they allow to simplify the nodes' mating.

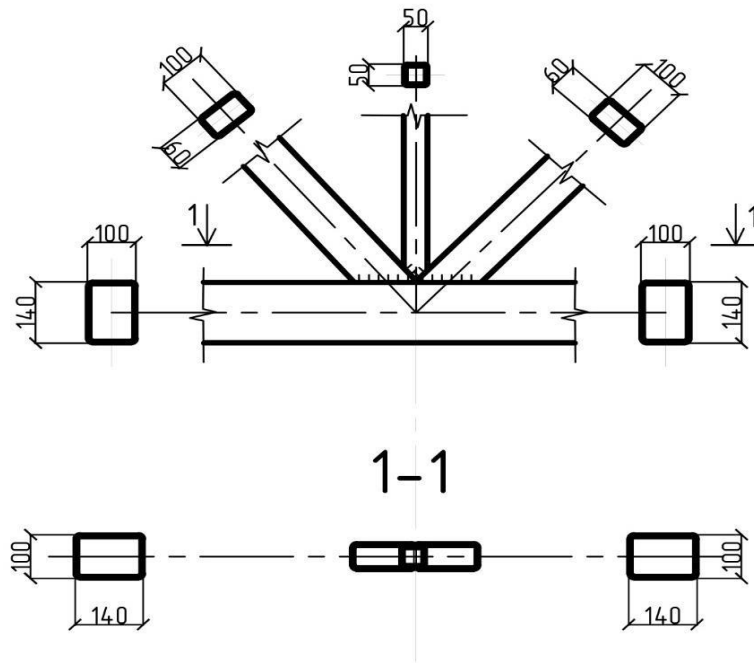

Figure 11. Node 4-4. The joint of the lower chord with the brace of the metal truss.

A honeycomb type of polycarbonate is used, the thickness of the plates of which is 10 mm, the specific weight is 1 kg / m<sup>2</sup>. Cellular polymer weighs 16 times lighter than glass. Thanks to the connecting profiles, the roof is airtight, durable and has an attractive appearance. Thanks to such a roof, it will be possible to reduce heat losses due to the low coefficient of thermal conductivity.

For cladding external walls that are above ground level, sandwich panels are used. Since the construction of the walls is made of metal pipes on which the sandwich panels are attached. In sandwich panels it is possible to use insulation Facade lamella. This insulation is a stone wool slab on a synthetic binder.

It is used when insulating areas with a curved surface.

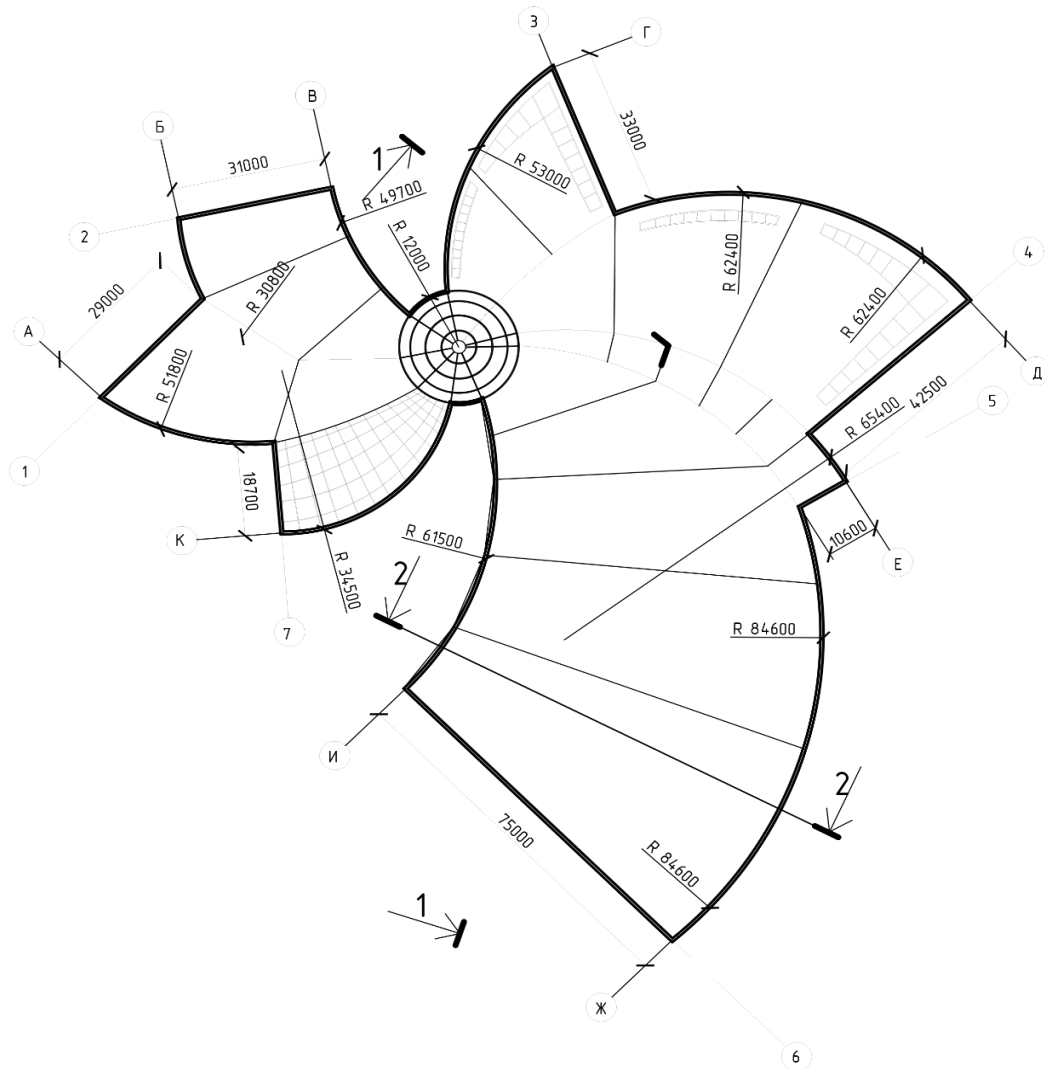

Figure 12

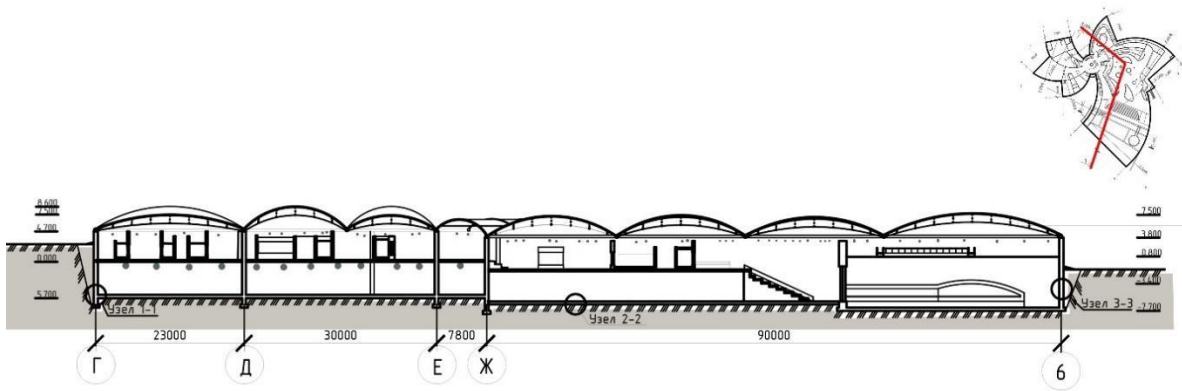

Figure 13. Section 1-1

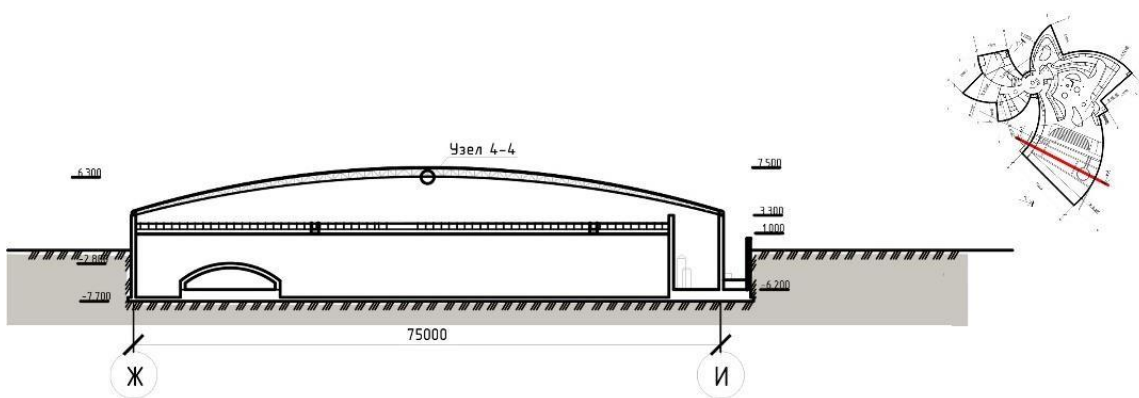

Figure 14. Section 2-2

## **6 Safety and labor protection**

### **6.1 General**

The goal of BZD in the design process is to achieve safety for prospective visitors to the public entertainment center.

The tasks of the Belarusian Railways are:

- creating comfortable conditions for finding a person.
- development of measures to protect people from such negative influences as fire, earthquake, destruction of an object, etc.
- ensuring the safety of technological processes during their design and operation.
- development of measures to prevent and eliminate the consequences of emergency situations.

Human life activity is called the process of existence, which is balanced with the process of realization of the individual, as well as instantaneous needs.

### **6.2 The main sections of life safety**

- Protection of a person in everyday life
- Protection of a person in the labor process
- Environmental protection

### **6.3 Ensuring safety along escape routes**

Protection of visitors to a public building on the escape routes is provided by a complex of space-planning, engineering, design and organizational measures.

Evacuation routes ensure the safe evacuation of people in the premises of buildings through emergency exits.

Evacuation exits are those exits that are from the premises of the first floor to the outside:

- directly
- through the corridor and staircase
- through the corridor
- through the lobby (foyer)
- through the staircase
- through the corridor and lobby (foyer)

When designing two or more emergency exits, they should be dispersed. This project provides nine emergency exits, which are located in each "petal" of the building.

The height of the doors on the escape routes is not less than 2 m, there are also arches between the rooms, the height of which is more than 2 meters.

#### **6.4 Fire protection**

According to clause 5.3.1.29. SN RK 3.02-07-2014 Public buildings and structures, each storage compartment must have evacuation exits, including a spare one. The project complies with this provision of the document and is shown in Fig.

According to clause 5.3.1.30 of SN RK 3.02-07-2014 Public buildings and structures, the doors of storage compartments must be fireproof.

Trading and viewing rooms without natural light are provided with smoke exhaust devices.

The project has an exit from the basement, which is an evacuation exit. Provided directly outside and separated from the general lobby of the building.

Public and residential buildings should be equipped with alarms or other fire warning systems. From the purpose and from the space-planning solution of the building, the methods of notification are determined.

Multifunctional buildings, the total building area of which is equal to or greater than 9 hectares, must be equipped with a roundabout drive along the building perimeter. The distance between the bypass curb and the buildings of the complex should not exceed 50 m.

## **6.5 Lighting**

According to the rules: the design of public premises without natural lighting is allowed to be placed: in the basement floors of the premises, in assembly halls, in conference rooms, in control rooms, in lecture halls, in sales areas of stores, in pantries, demonstration rooms, etc.

Street lighting helps a person to recognize an impending threat in a timely manner. For this, it must be sufficient, not too bright, which can blind a person, and correctly directed, etc.

Also, in the project, the pedestrian alleys are illuminated by street lamps, which are located in a row on both sides. But in squares, the lanterns are located in a circle, or have an arc arrangement on the plan. The project also provides for the location of lanterns on the embankments and quays, for convenience and comfortable walking along the lake and the correct approach of the boat to the quays at late hours of the day. To maintain safety on the stairs in the park, lamps are installed that are built into the riser, thus illuminating the entire staircase.

Small lamps are placed on the classic lawn, which will illuminate the green grass and create a fabulous mood for park visitors in the evening.

## **6.6 Protection of the territory from the harmful effects of noise**

In the process of designing the center and its improvement, initially it is necessary to take into account the solution of the problems of noise protection.

There are 3 methods to solve these problems:

1. Engineering and administrative methods - for the noise source.
2. Along the trajectory, from noise sources to the object itself - acoustic and urban planning.
3. At the facility itself - structural and construction (improving the soundproofing quality of the fence structures).



## 6.7 Social protection in the entertainment center

An entertainment center for people of all ages is an object of mass congestion, and must be equipped with burglar alarms, access control systems (except for the first zone), warning systems and video surveillance systems

The system for control and management of access ensures the organization in the access and in the object solution at the facility, and divides it into the following access zones:

- the first zone - a building, territory, premises with unlimited access for staff and visitors;
- the second zone - premises with access for the limited staff of the center, as well as for visitors with one-time passes or accompanied by the administration;
- the third zone - the premises of the center, with access for a strictly defined number of employees and managers.

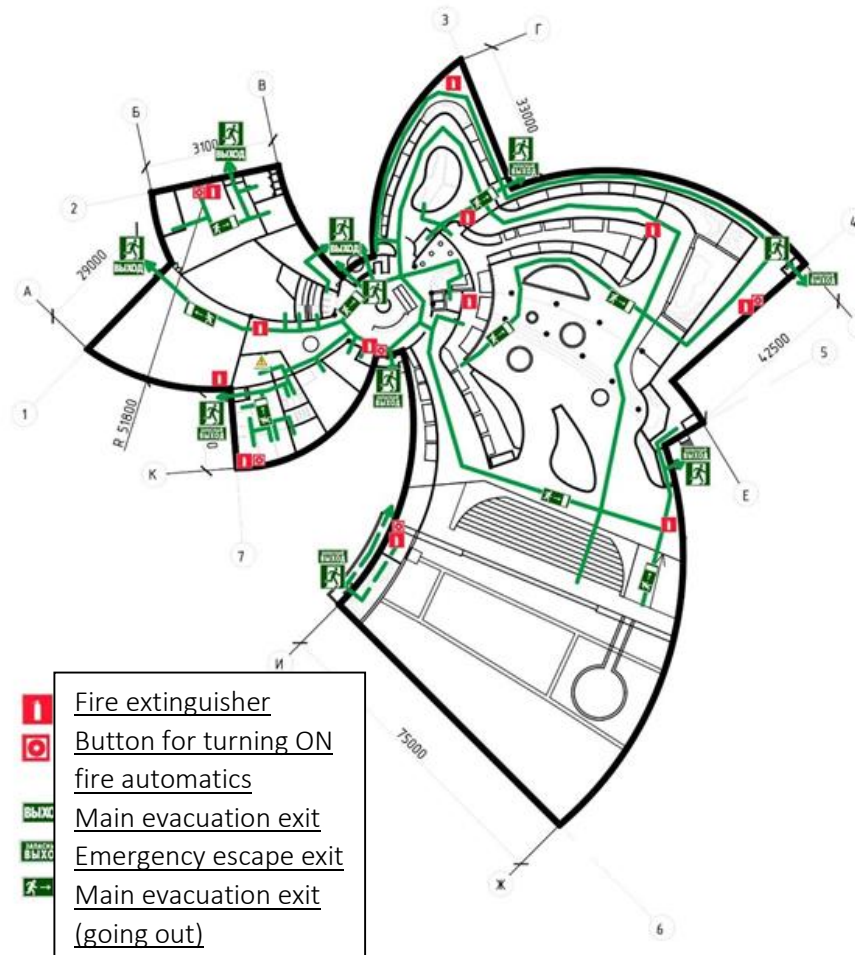

Figure 15

## CALCULATION PART

### 7 Vertical stiffness diaphragm

#### 7.1 Guidelines for calculating vertical stiffness ties

The spatial stability of the building can be ensured by a frame system if the crossbars are installed between the columns in the longitudinal direction as well as in the transverse direction, i.e. to be rigidly embedded in the columns to ensure the perception of horizontal forces. In this case, the joints of the columns with the girders in two directions are complex. If, according to the terms of the layout of the premises, partitions are provided, then in their plane it is possible to put vertical stiffness ties, replacing the crossbars of the longitudinal direction. Connections can be lattice metal and solid reinforced concrete (diaphragms) with or without openings. The latter are distinguished by lower metal consumption. In addition to being calculated in the longitudinal direction as a cantilever equal to the height of the building, vertical diaphragms must be checked for stability from the plane of the wall within the height of one floor. For simplicity, vertical diaphragms can be considered loosely fixed in the floor levels without being connected to the columns.

#### 7.2 Collecting loads

Wind pressure over the projection area of the building at a height of up to 10 m –

$$w_1 = 0.275 \text{ kH}/\text{M}^2, \text{ till } 20 \text{ m} - w_2 = 0.381 \frac{\text{kH}}{\text{M}^2}.$$

Total forces in the section along the edge of the foundation from the wind load acting in the direction of the longitudinal axis of the building on the facade wall with a length of  $L = 62.4 + 0.4 + 2 \times 0.3 = 65.1$  m and a height of  $H = 24 + 0.6 = 24.6$  m (here 0.4 m is the width of the column; 0.3 m - thickness of wall panels; 0.6 m - height of the contour of the combined roof).

Transverse force

$$Q_w = 65.1 \times [10 \times 0.275 + (24.6 - 10)0.381] = 541 \text{ kH}$$

Bending moment

$$M_w = 65.1 \times \left[ 0.275 \times \frac{10^2}{2} + 0.381 \times 14.6(10 + 0.5 \times 14.6) \right] = 7159 \text{ kH}$$

These forces are absorbed by two diaphragms located between the middle columns of the transverse frames and assembled from panels measuring  $5.6 \times 6$  m with a thickness of 0.2 m from concrete of class C12 / 15. For the consumption of materials in prefabricated

panels, it is possible to provide round vertical voids  $D = 80$  mm, which are used as channels for communication. For example, the volume of forty voids in one panel (floor)

$$\pi \times 0.04^2 \times 4 \times 40 = 0.8 \text{ m}^3.$$

Reinforced concrete panel weight

$$G = (4 \times 6.18 \times 0.2 - 0.8)2.5 \times 9.8 = 100 \text{ kH}$$

Diaphragm weight of five panels

$$N = 5 \times 100 = 500$$

Plan and side view of the stiffening diaphragm in accordance with

### 7.3 Calculation of a vertical diaphragm with a height of 24m

Console calculated length  $l_0 = 2M = 2 \times 24 = 48$  m. For class B10 concrete  $f_{ck} = 12$  MPa;  $f_{cd} = 6.8$  MPa;  $E_b = 24000$  MPa;  $\gamma_{b2} = 0.9$   
 Armature class S500  $\emptyset 10...40$  c  $f_{yd} = 435$  MPa;  $E_s = 200000$  MPa.

$$\delta_e = \frac{e_0}{h} \quad (4.1)$$

But no less relative eccentricity, which is determined by the formula from 6.2 [2]:

$$\delta_{e,min} = 0.5 - 0.01 \left( \frac{l_0}{h} + \gamma_{b2} f_{cd} \right) \quad (4.2)$$

The influence of the duration of the action of the load on the deflection at the eccentricity of its action is taken into account by the coefficient according to the formula from 6.3 [2]:

$$\varphi_l = 1 + \beta N_1 \frac{e_{0l} + 0.5h - a}{N(e_0 + 0.5h - a)} \quad (4.3)$$

$\beta$  - coefficient taken depending on the type of concrete according to table 30 [4]  
 $N_1$  — the same, from the action of constant and longed loads

$$\varphi_l = 1 + \frac{3070 - 400}{7159 + 2670} = 1.4$$

With symmetric reinforcement

$$\xi = \frac{500000}{0.9 \times 6.8 \times 200(6180 - 400)} = 0.07$$

$$x = 0.07 \times 5740 = 400 \text{ mm}$$

For the reduced I-section minus the voids

$$\begin{aligned} b'_f &= 200 \text{ mm}; b = 200 - 80 = 120 \text{ mm}; h'_f = 690 \text{ mm}; I \\ &= \left[ 200 \times \frac{690^3}{12} + 200 \times 690 \times (3070 - 345)^2 \right] 2 \\ &+ \frac{120(6180 - 2 \times 690)^3}{12} = 314 \times 10^{10} \text{ mm}^4 \end{aligned}$$

Minimum reinforcement determined using table 38 [2] for flexibility

$$\lambda = \frac{40000}{6180} = 6.5$$

$$A'_s = A_s = 0.002 \times 120 \times 5740 = 1378 \text{ mm}^2$$

Conditional critical force, determined by the formula 6.4 [2]:

$$N_{cr} = \frac{6.4E_b}{l_0^2} \left[ \frac{I}{\varphi_l} \left( \frac{0.11}{0.1 + \delta_e/\varphi_p} + 0.1 \right) I_s E_s/E_p \right] \quad (4.4)$$

$$N_{cr} = \frac{6.4 \times 224000}{4000^2} \left[ \frac{314 \times 10^{10}}{1.4} \left( \frac{0.11}{0.1 + 1.2} + 0.1 \right) + 1927 \times 10^8 \times 8.3 \right]$$

$$= 55440 \text{ kH}$$

The value of the coefficient  $\eta$ , which takes into account the influence of the deflection on the value of the eccentricity of the longitudinal force  $e_0$ , should be determined by the formula 6.5 [2]:

$$\eta = \frac{1}{1 - \frac{N}{N_{cr}}} \quad (4.5)$$

$$\eta = \frac{1}{1 - \frac{300}{55440}} = 1.01$$

$$e = 1.01 \times 7159 + 0.5 \times 6180 - 400 = 7478 \text{ mm}$$

The required symmetric reinforcement according to the formula 6.6 [2]:

$$A'_s = A_s = \frac{N[e - (1 - 0.5\xi h_0)]}{[f_{yd}(h_0 - a')]} \quad (4.6)$$

$$A'_s = A_s = \frac{500000[7478 + (1 - 0.5 \times 0.07)5740]}{[435(5740 - 400)]} = 420 \text{ mm}^2 < 1378 \text{ mm}^2$$

Structural reinforcement remains 8Ø16 S500 c  $A_s = 1378 \text{ mm}^2$  on every face.

Strength calculation of the diaphragm section inclined to the longitudinal axis.

$$Q = 214 \text{ kH}; N = 500 \text{ kH.}$$

Checking the strength condition of the inclined strip between cracks according to the formula 6.7 [2]:

$$\varphi_{w1} = \frac{Q}{[0.3(1 - \beta \times f_{cd})\gamma_{b2} \times f_{cd} \times b \times h_0]} \quad (4.7)$$

$$\varphi_{w1} = \frac{214000}{[0.3(1 - 0.01 \times 6.8)0.9 \times 6.8 \times 120 \times 5740]} = 0.18 < 1.4$$

Coefficient taking into account the influence of longitudinal compressive force on the bearing capacity of an inclined section

$$\varphi_n = 0.1 \times \frac{500000}{0.9 \times 0.73 \times 120 \times 5740} = 0.11$$

Transverse force perceived by concrete according to the formula 6.8 [2]:

$$Q_{b0} = \varphi_b (1 + \varphi_f + \varphi_n) \gamma_{b2} \times f_{cd} \times b \times h_0 \quad (4.8)$$

$$Q_{b0} = 2(1 + 0.11)0.9 \times 0.73 \times 120 \times \frac{5740}{2} = 500 \text{ kH} > Q = 214 \text{ kH}$$

Consequently, transverse reinforcement is not required by design

#### 7.4 Calculation of the diaphragm section within the floor

$$\text{Random eccentricity } e_{a1} = \frac{4800}{600} = 6.7 \text{ mm} = e_{a2} = \frac{200}{30} = 6.7 \text{ mm}$$

$$\delta_e = \frac{6.7}{200} = 0.03 < \delta_{e,min} = 0.5 - 0.01 \left( \frac{4800}{200} + 0.9 \times 6.8 \right) = 0.24$$

$$\varphi_l = 1 + \frac{100 - 30}{6.7 + 70} = 1.9$$

$$I = 6180 \times \frac{200^3}{12} - 30 \times 80 \times \frac{80^3}{12} = 3990 \times 10^6 \text{ mm}^4.$$

$$\text{Minimal reinforcement with flexibility } \lambda = \frac{4800}{200} = 24$$

$$A'_s = A_s = 0.0025 \times 6180 \times 170 = 2610 \text{ mm}^2$$

$$I_s = 2 \times \frac{2610(170 - 30)^2}{4} = 26 \times 10^6 \text{ mm}^4$$

Conditional critical force, determined by the formula 6.4 [2]:

$$N_{cr} = \frac{6.4 \times 24000}{4800^2} \left[ \frac{3990 \times 10^{10}}{1.9} \left( \frac{0.11}{0.1 + 0.24} + 0.1 \right) + 26 \times 10^6 \times 8.3 \right] \\ = 10600 \text{ kH}$$

The value of the coefficient  $\eta$ , which takes into account the influence of the deflection on the value of the eccentricity of the longitudinal force  $e_0$ , should be determined by the formula 6.5 [2]:

$$\eta = \frac{1}{1 - \frac{500}{10600}} = 1.05$$

$$e = 1.05 \times 6.7 + 70 = 78 \text{ mm}$$

The relative height of the compressed zone of concrete

$$\xi = \frac{500000}{0.9 \times 6.8 \times 6180 \times 170} = 0.08$$

$$A'_s = A_s = \frac{500000[78 - (1 - 0.5 \times 0.08)170]}{435 \times 140} < 0$$

According to the calculation, the reinforcement is not required, but it is assigned for structural reasons  $A'_s = A_s = 2610 \text{ mm}^2$ . In addition to the previously defined aperture  $8\emptyset 16$  S240 c  $A_s = 1608 \text{ mm}^2$  need to add  $\Delta A_s = 2610 - 1608 = 1002 \text{ mm}^2$ . With a distance between the rods  $S = 200 \text{ mm}$ , the required cross-sectional area of each  $A_s = 1002 \times \frac{200}{6180 - 400} = 34.5 \text{ mm}^2$ , for example  $1\emptyset 8$  A-III c  $A_s = 50.3 \text{ mm}^2$ .

Checking the strength of the section inclined to the longitudinal axis of the panel: at random eccentricity  $e_a = 6.7 \text{ mm}$  bending moment  $M = Ne_a = 500000 \times 6.7 = 3350000 \text{ H} * \text{mm}$ , by its magnitude, it is possible to determine the lateral force for a beam freely lying on the supports at  $l_0 = 4800 \text{ mm}$ :

$$Q = \frac{4M}{l_0} = 4 \times \frac{5000000}{4800} = 1041 \text{ H}$$

$$\text{Coefficient } \varphi_n = 0.1 \times \frac{500000}{0.9 \times 0.57 \times 5540 \times 170} = 0.146$$

Transverse force perceived by concrete according to the formula 6.8 [2]:

$$Q_{b0} = 2(1 + 0.11)0.9 \times 0.73 \times 6180 \times \frac{170}{2} = 716213 \text{ H} > Q = 1041 \text{ H}.$$

Transverse reinforcement parallel to the narrow panel edges is not required by design. It is only necessary to supply structural transverse reinforcement -  $6 \emptyset$  S240 in the plane of the diaphragm with a step -  $S = 2 \times 200 = 400 \text{ mm}$ , i.e. diaphragm panels are reinforced with meshes -  $200/400/8/3$  with extreme rods -  $4 \times 3 \emptyset 16$  A-III, joined by welding at the junction of the panels. Prefabricated diaphragm panels must be checked for the forces that arise during lifting, transportation and installation.

## TECHNOLOGICAL PART

### 8.1 Formwork installation

The quantity of formworks is equal to the area of the surfaces form. It is necessary to count the area of rectangular side faces of the foundation and trapezoidal inner glass surfaces.

The scheme of foundations reinforcement, type of reinforcement structures and reinforcing bars consumption in real conditions is included in the working drawings of the foundations. In the Course Project the amount of reinforcement work is defined as follows. Accepted the foundation reinforcement in the form of a horizontal grid at the bottom and vertical spatial frame at the entire height of the concrete preparation to the top of column footing.

### 8.2 Concreting of foundations

Concrete works quantity:

Concrete quantity in the foundations is determined by geometry formulas with the use of plan and foundation section drawn earlier

For the strip foundation:

$$V_{s/f}=(h_f (s) \cdot 0,3 \cdot P_{base.}) + (h_f (b) \cdot 0,8 \cdot P_f), m^3 \quad (16)$$

where,  $V_{s/f}$ — volume of strip foundation,  $m^3$ ;

$h_f (b)$ — the height of the foundation

base, ref. monolithic strip foundation section;

$h_f (s)$ — the height of the structure basement, ref. monolithic strip foundation section;

$P_f$  — total foundation length per the scheme (8 page).

$$V_{s/f}=( 3.4 \cdot 0,3 \cdot 4.) + (0.3 \cdot 0,8 \cdot 4) = 5.04 m^3$$



### 8.3 Foundation waterproofing

In the course project adopted the following form of waterproofing – waterproofing coating. Painting is done by applying bituminous mastics to the surface to be painted. The number of applied layers is 2. Waterproofing is carried out in accordance with E4-3- 184.

For the strip foundation:

To calculate the amount of work necessary to find the surface waterproofing area.

$$S_{\text{waterproof}} = [(h_{f(s)} \cdot P_{\text{exterior walls}}) + (0,25 + 0,3) \cdot P_{\text{exterior walls}}] \cdot 2, \text{ m}^2$$

where,  $h_{f(s)}$  – the height of the structure basement, ref monolithic strip foundation section (figure.3)

$P_{\text{exterior walls}}$  – perimeter of the exterior walls of the building.

$$S_{\text{waterproof}} = [(3,4 \cdot 2025) + ((0,25 + 0,3) \cdot 2025)] \cdot 2 = 14904 \text{ m}^2$$

### 8.4 Backfilling

The volume of soil to be backfilled in the pit gaps, in structures with basements is calculated by the formula

(for pit):

$$v_{b.f} = \frac{v_p - v_{s/f} - v_{cellular}}{1 + K_{rl}}$$

where,  $V_{s/f}$  – volume of strip foundation,  $\text{m}^3$

$V_{cellar}$  – volume of cellar:

$$V_{cellar} = l_1 \cdot l_2 \cdot h_{f(b)}, \text{m}^3$$

$$V_{cellar} = 54 \cdot 54 \cdot 0,3 = 874,8 \text{m}^3$$

$K_{rl}$  – Index of residual soil loosening .

$h_{f(s)}$  – the height of the structure basement, ref. monolithic strip foundation section;

$$v_{b.f} = \frac{12334,77 - 5,04 - 974,45}{1 + 1,05} = 5539,16$$

## 8.5 Soil compaction

Compaction volume is measured mainly by the area of compaction that can be found, given by the average value of the compacted layer thickness (for the pit):

$$v_{com} = \frac{v_{bf}}{h_c} m^2$$

$V_{bf}$  – backfilling volume,  $m^3$ ;

$h_c$  – compacted layer thickness, 0,2÷0,4 m.

$$v_{com} = \frac{5539.16}{0.3} = 18463.87 m^2$$

## 8.6 Final land planning

The final planning is made after the completion of all excavations and communication devices (for the pit):

$$S_{planning} = S_{1(a)} - S_{building}, m^2$$

where,  $S_{1(a)}$  – cutting area of the vegetation layer of the pit (trench)

$S_{building}$  – area of the building.

$$S_{planning} = 6496.36 - 2916 = 3580.36 m^2$$

$$S_{building} = l_1 \cdot l_2, m^2$$

where,  $l_1, l_2$  – length and width of the structure in plan, respectively (per the task), m.

$$S_{building} = 54 \cdot 54 = 2916 m^2$$

## 8.7 Removal of temporary fencing

After finishing the construction work necessary to remove the construction temporary fencing, fencing perimeter determined by the formula (for the pit):

$$P_{fen} = (20 + l_1) \cdot 2 + (20 + l_2) \cdot 2, m$$

where,  $l_1, l_2$  – length and width of the structure in plan, respectively (per the task), m  
Distance from the axis of the building in each direction is 20 m.

$$P_{fen} = (20 + 54) \cdot 2 + (20 + 54) \cdot 2 = 296 m$$

## 9 Method choice of complex mechanized earthworks process

During the comprehensive mechanization, the processes are performed by machine sets, complementing each other and linked to each other on the basic parameters and the location in the processing chain.

When choosing methods of production work to be considered: the type of soil, the size of earth construction, the groundwater level, the range of soil haulage and the season of the work.

Excavation and haulage of soil during pits and trenches excavation can be carried out by bulldozers, excavators, in set with dump trucks.

The choice of a complex– mechanized production process of excavation is carried out on the basis of technical and economic comparison of options of different sets of machines. For comparison to be chosen 2–3 cars of one or different types.

In the Course Project it is necessary to implement options comparison per the leading earthmoving machine.

Top soil removal is carried out by bulldozers or scrapers. When choosing types of machines must be taken into account that the process actually involves topsoil removal and soil transportation. Bulldozers to be used preferably to move the soil at a distance of 50–150 meters (depending on the power of a bulldozer). Maximum efficiency is achieved when moving soil at the following distances: for bulldozer on the basis of tractors DT–74, DT–75, T–4AP1 – 30–50 m

on the basis of tractors T–100, T–130 – 50–70 m; on the basis of tractors T– 180, DET250, T–330 – up to 150 m.

During design of top soil removal by earthmovers, to be set the haulage distance of topsoil and in accordance with this distance to select the brand of bulldozer or scraper, using the recommendations trough the construction practice and machine specifications.

Earthmovers recommended for top soil removal with the different distance of topsoil haulage table.3.

(The average distance of soil haulage)	(Up to 50)	50...70	70...150
(Recommended equipment)	(Bulldozer on the tractor basis with the power, kW (l.s))		
(Equipment features )	(Up to 59)	80...108	108...130

We choose bulldozer on the tractor basis with the power 50-70 kw  
 Because of 3 km soil transportation I choose tractor (T-74) and bulldozer (DZ-29)

Shift operating of the bulldozer is calculated per the formula

$$p_{sh.o} = \frac{60 * T * q * \alpha * C_{time}}{T_1 + T_s + \frac{L_r}{V_r} + \frac{L_n}{V_n}}$$

where T – bulldozer working hour in a shift, 8h

q – the soil volume moved with a dump, m<sup>3</sup>

α – factor, including the loss of soil in the process of haulage, α = 1 + 0,005 ·

$l_r$

$$\alpha = 1 + 0,005 \cdot 3 = 1.015$$

$C_{time}$  – factor of the equipment usage in time (during haulage of loosened rock material 0,75 in other cases – 0,8)

$T_l$  – time for a set of soil category, min

$T_s$  – time spent on switching speeds, min

$l_r, l_n$  – estimated haulage distance with the load and empty,  $l_r = l_n$ , is determined by each student individually

$V_r, V_n$  – bulldozer speed during soil transportation (charged) and forward drive (empty), m / min

$$p_{sh.o} = \frac{60 * 8 * 60 * 0.52 * 1.015 * 0.75}{0.36 + 0.09 + \frac{3}{5.1} + \frac{3}{7.1}} = 10556 \text{ min}$$

## 10 Selection of the excavator

Selection of excavator depends on the soil volume in the pit to determine the cost of  $1m^3$  of soil in the pit (trench) for each excavator type:

Soil volume in pit 6000-11000

Capacity of excavator 0.8 so type of excavator (EP-1A)

$$C_{(1,2)} = \frac{1.08C_{eqp-shift}}{p_{shf.pr}}$$

where 1,08– factor including overheads

$C_{eqp.-shift}$  – cost of equipment– shift of excavator

$P_{shf.pr.}$  – excavator shift production, including soil excavation for dump and with loading in vehicles.

Shift production can be calculated by the following formula:

$$P_{shf.pr.(1,2)} = \frac{V_{k(tr)}}{\sum N_{qp-shift}}$$

where,  $\sum N_{qp-shift}$ – total number of equipment–shifts of excavator

For the pit:

$$\sum N_{qp-shift} = \frac{V_{tr}}{100} H_{sd}$$

where  $H_{sd}$ – standard duration of the excavation cycle

$V_{p(tr)}$ –soil quantity of the pit

$V_{tr.a.}$ –access trench quantity

To be determined the specific capital investments for the development of  $1m^3$  of soil in the pit (trench) for each type of excavators:

$$C_{sp.(1,2)} = \frac{1.07C_{i.e}}{P_{shf}}$$

where,  $C_{i.e.}$  – inventory–estimated cost of excavator

$P_{shf.}$  – number of excavator work shifts in a year.

Approximately it can be accepted as 350 shifts for machines with bucket capacity of up to  $0,65m^3$  inclusive and 300 –for the bucket more than  $0,65m^3$ .

The final selection of the excavator is produced on the basis of comparison of specific reduced development costs of  $1m^3$  of soil:

$$P_{sp.(1,2)} = C_{(1,2)} + (En \cdot C_{sp(1,2)})$$

where,  $E_n$  – normative factor of effectiveness of capital investments, equal to 0,15.  
The operational capacity of the excavator is calculated using the formula:

$$P_{sh.o.} = T \cdot 60 \cdot g \cdot n \cdot K_l \cdot K_b$$

where  $T$ —shift duration, 8 hour

$g$  –bucket volume

$n$  – number of cycles per minute<sup>60</sup>

$K_l$  – bucket volume usage factor

$K_b$  – shift percent uptime (0,8–0,85)

$t_c$  – time of one cycle

### **Selection of mechanisms for soil compaction**

Soil compaction work in the pits are implemented in two steps:

I– soil compaction between the columns foundations

II – over the columns foundations

Depending on the lack of space of works performance conditions, can be used:

-motor rollers with smooth rolls – for cohesive soil.

-vibroroller– for non–cohesive soils.

-hydraulic–mechanical vibratory compactors – for all soils.

-electrical self–moving vibrating rammer – for non–cohesive and lowly cohesive soils.

-electrical rammer – for cohesive and non–cohesive soils

Shift operating performance of rollers is calculated by the formula:

$$P_{sh.o.} = \frac{(B - b) \cdot v \cdot 1000 \cdot h \cdot T}{m} \cdot 0.85$$

where  $B$ – width of compaction line

$b$  – width of overlap of adjacent lines (0,1–0,2 m)

$v$  – average speed (4–6 km / h)

$h$  – width of the condensed layer, m

$m$ – required number of blows or passes (8...10)

The composition of the machines included in the set to be determined by estimated (operational performance) and selected on the basis of the requirement for mechanization of all processes in the Volume of works, the usage of a minimum number of machines in the set, compliance with the specified flows of excavation in shift.

Table-4 cost calculations of machine time, labour costs and salary

(Name of processes)	(Volume of work)		Labour cost, h-d	(The required cars)		(Duration of, days(P))	Number of changes (A)	(Number of workers in change)	Structure of crew)	(Working schedule)											
	Unit measurements	Quantity		(The required cars)	(Number <i>shf.pr.</i> )					Days, month											
										1	2	3	4	5	6	7	8	9	10		
1	2	3	4	5	6	7	8	9	10												
The construction of temporary fencing	M	332	398.4	1	1	2	2	10			2										
Soil excavation in the (trench) and trench access to the pit	M³	8568	54492	2	2	3	2	8				3									
Excavation of soil shortage	M³	400.32	656.4	1	2	4	2	9					4								
Concrete preparation for foundations	M³	10.8	8.53	1	1	3	2	5						3							
Reinforcement installation	t	141.55	2617.7	1	1	10	2	10							10						
Formwork installation	M²	212.16	110.25	1	1	9	2	7								9					
Concreting of foundations	M³	298.4	456.5	2	2	6	2	10									6				
Formwork removal	M²	746.2	253.6	2	1	3	2	5												3	
Foundation waterproofing	M²	732.4	7324	2	2	2	2	10												2	
Backfilling	M³	4073.7	1588.7	2	2	3	2	10												3	
Soil compaction	M²	13579	12492	2	2	5	2	10													5
Final land planning	M²	1360	1115.2	1	2	1	2	10												1	
Removal of temporary fencing	M	332	298.8	1	1	2	5	5												2	

(Name of processes)	(Justification on (ENIR, No., table, point))	Unit of measure	Volume Of work	Standard time		Quotation, u.e.		Labor costs		Salary	
				Working h-h	Drivers Of m-cm	working	Drivers	Working h-d	Drivers Of m-cm	working	drivers
The construction of temporary fencing		10M(m)	332	1,2	–	1,3		398.4	-	517.9	-
Removal of top soil		1000 M(m)2	5248	–	0.56	–	0.6	-	2938.8	-	1763.3
Soil excavation in the pit (trench) and trench access to the pit		100 M(m)2	8568	2.8	3.56	1.48	1.7	23990	30502	35505	51853
Excavation of soil underrun		M(m)3	400.3	1.64	–	0.54	–	656.4	-	354.4	-
Concrete preparation for foundations		M(m)3	10.8	0.79	–	0.49	–	8.53	-	4.18	-
Reinforcement installation of strip foundation manually		T	141.5	18,5	–	14	–	2617.7	-	36647	-
Formwork installation of strip foundation		M(m)2	212.16	0,37	0,15	0,13	0,10	78.45	31.8	10.19	3.18
Concreting of strip foundation		M(m)3	298.4	0,88	0,65	0,22	0,23	262.6	193.9	57.77	44.59
Formwork removal of strip foundation		M(m)2	746.2	0,19	0,15	0,47	0,10	141.7	111.9	66.6	11.2
Foundation waterproofing		100M(m)2	732.4	10	–	7,15	–	7324	-	-	52366
Backfilling		M(m)2	4073.7	–	0,39	–	1,58	-	1588.7	-	2510
Soil compaction		100 M(m)2	13579	–	0,92	–	0,26	-	12492	-	3248
Final land planning		100 M(m)2	1360	0,33	0,49	1,58	1,65	448.8	666.4	709.1	109.5
Removal of temporary fencing		10M(m)	332	0,90	–	1,05	–	298.8	-	313.7	-



## CONCLUSION

The improvement project was developed in accordance with the rules for the design and improvement of the territory of settlements also with the existing situation at the facility. The total area of the territory for improvement is 110 hectares.

To solve the set tasks, the following measures were proposed for the improvement and beautification of the territory in places of various useful activities:

- Updating and adding sports grounds -Installing playgrounds.
- Adding a new type of playground.
- Organization of the summer theater.
- Creating conditions for the development of small business: installation of modular structures in a single style. Implementation of business ideas (rope park, cafes, souvenir shops, bicycle rentals in the summer and bagel rentals in the winter, etc.)

Also, the project will have a positive impact on the sustainable development of the city, as conditions are created for small and medium-sized businesses in the service sector, therefore, support for entrepreneurial initiatives of young people; reorganization of engineering and communal infrastructure; renewal and organization of new leisure activities. The location on the sites of entrepreneurs automatically makes the territory safe and well-groomed.

In conclusion, I can say that the implementation of the project will only have a positive impact on residents and guests of the city. Since the project meets important indicators: first safety, second environmental friendliness, third transport accessibility, and the last is the ability to meet different needs and various requests for people's leisure.

## REFERENCES

1. СНиП РК 2.04-01-2011. Construction climatology
2. СП РК 3.01-101-2013. Urban planning. Planning and development of urban and rural settlements
3. СНиП РК 3.01-03-2010. Rules for the improvement of the territories of settlements
4. СН РК 3.02-07-2014. Public buildings
5. СНиП РК 2.02-05-2012. Fire safety of buildings and structures
6. Climatic structures design analysis
7. Recommendations TSNSHEP theme. On design of museums
8. Designing textbook for the discipline “Engineering equipment of sanitary facilities in public buildings”
9. General requirements for fire safety
10. РК 2.04-02-2011 Natural and artificial lighting

### **Additional literature**

11. <https://www.bibliofond.ru/view.aspx?id=889956>
12. <https://lektsii.net/4-42059.html>
13. <http://tehlib.com/arhitektura/gradostroitel-stvo/ozelenenny-e-territoriiobshhego-pol-zovaniya/>
14. <https://yandex.ru/images>
15. <https://studbooks.net>
16. <http://www.pogodaiklimat.ru/climate/36870.htm>
17. [https://thearchitect.pro/ru/news/6366v\\_parke\\_zaryade\\_nachali\\_blagoustrojstvo\\_peshehodnoj\\_zony](https://thearchitect.pro/ru/news/6366v_parke_zaryade_nachali_blagoustrojstvo_peshehodnoj_zony)
18. <https://kazan-tour.info/obzor/park-tysyacheletiya-millenium/>

**RESPONSE**

**OF THE  
SUPERVISOR**

for the graduation project

Naikpay Ramin

5B072900-Civil Engineering

Topic: «Shopping and entertainment complex in Shymkent»

Graduation project of Naikpay Ramin made in accordance with the requirements and includes all the necessary sections of the diploma project.

In the Architectural part, facades, sections, floor plans and connection nodes of structures are presented. The thermotechnical calculation of the wall fencing was made.

In the constructive section, the calculation of the diaphragm on the LIRA CAD program is performed. In the technological part, technological maps for earthworks and formworks works have been developed.

The economic part of the project is calculated according to the program of ABC. All drawings are made in Autocad.

In general, the graduation project was performed at a good level, the student Naikpay Ramin showed good knowledge both during training and during the implementation of the project. The work deserves a good grade.

**Supervisor**

Master of technical science, lecturer

\_\_\_\_\_ Mukhanbetzhanova Zh.Sh.

«30» may 2021 yr.

## Протокол анализа Отчета подобия Научным руководителем

Заявляю, что я ознакомился(-ась) с Полным отчетом подобия, который был сгенерирован Системой выявления и предотвращения плагиата в отношении работы:

**Автор:** Наикпай Рамин

**Название:** Shopping and entertainment complex in Shymkent

**Координатор:** Надежда Козюкова

**Коэффициент подобия 1:**6.1

**Коэффициент подобия 2:**4.4

**Замена букв:**44

**Интервалы:**0

**Микропробелы:**0

**Белые знаки:** 0

**После анализа Отчета подобия констатирую следующее:**

- обнаруженные в работе заимствования являются добросовестными и не обладают признаками плагиата. В связи с чем, признаю работу самостоятельной и допускаю ее к защите;
- обнаруженные в работе заимствования не обладают признаками плагиата, но их чрезмерное количество вызывает сомнения в отношении ценности работы по существу и отсутствием самостоятельности ее автора. В связи с чем, работа должна быть вновь отредактирована с целью ограничения заимствований;
- обнаруженные в работе заимствования являются недобросовестными и обладают признаками плагиата, или в ней содержатся преднамеренные искажения текста, указывающие на попытки сокрытия недобросовестных заимствований. В связи с чем, не допускаю работу к защите.

Обоснование:

.....

.....  
*Дата*

.....  
*Подпись Научного руководителя*

**Протокол анализа Отчета подобия**

**заведующего кафедрой / начальника структурного подразделения**

Заведующий кафедрой / начальник структурного подразделения заявляет, что ознакомился(-ась) с Полным отчетом подобия, который был сгенерирован Системой выявления и предотвращения плагиата в отношении работы:

**Автор:** Наикпай Рамин

**Название:** Shopping and entertainment complex in Shymkent

**Координатор:** Надежда Козюкова

**Коэффициент подобия 1:6.1**

**Коэффициент подобия 2:4.4**

**Замена букв:44**

**Интервалы:0**

**Микропробелы:0**

**Белые знаки:0**

**После анализа отчета подобия заведующий кафедрой / начальник структурного подразделения констатирует следующее:**

- обнаруженные в работе заимствования являются добросовестными и не обладают признаками плагиата. В связи с чем, работа признается самостоятельной и допускается к защите;
- обнаруженные в работе заимствования не обладают признаками плагиата, но их чрезмерное количество вызывает сомнения в отношении ценности работы по существу и отсутствием самостоятельности ее автора. В связи с чем, работа должна быть вновь отредактирована с целью ограничения заимствований;
- обнаруженные в работе заимствования являются недобросовестными и обладают признаками плагиата, или в ней содержатся преднамеренные искажения текста, указывающие на попытки сокрытия недобросовестных заимствований. В связи с чем, работа не допускается к защите.

**Обоснование:**

.....

.....

.....

.....

.....

.....

.....

Дата

*Подпись заведующего кафедрой /*

*начальника структурного подразделения*

**Окончательное решение в отношении допуска к защите, включая обоснование:**

.....  
.....  
.....  
.....  
.....  
.....  
.....

Дата

*Подпись заведующего кафедрой /*

*начальника структурного подразделения*